

***THERMOSTAT  
Owner's Guide  
and  
Installation Instructions***



**Domestic Mains Pressure  
Electric Boosted Solar Water Heater**

**SE260 to SE415 Series**

**⚠ Warning: Use copper pipe ONLY. Plastic pipe MUST NOT be used.**

It is a requirement of a solar water heater installation that all pipe work be in copper and not plastic, due to the effects of high water temperatures and pressures.

*This solar water heater must be installed and serviced by a qualified person.  
Please leave this guide with the householder.*

** Warning: Important notes for plumber.**

For installation requirements critical for correct operation of the solar water heater, refer to 'Warning: Important Notes for Plumber' on page 26.

---

**⚠ Warning:** Upon completion of the installation and commissioning of the solar water heater, leave this guide with the householder or responsible officer. **DO NOT** leave this guide inside the cover of the solar control unit or solar storage cylinder, as it may interfere with the safe operation of the solar water heater or ignite when the solar water heater is turned on.

---

#### **Patents**

This solar water heater may be protected by one or more patents or registered designs in the name of Aquamax Australia Pty Ltd or Rheem Australia Pty Ltd.

#### **Trade Marks**

® Registered trademark of Aquamax Australia Pty Ltd.

™ Trademark of Aquamax Australia Pty Ltd or Rheem Australia Pty Ltd.

**Note:** Every care has been taken to ensure accuracy in preparation of this publication. No liability can be accepted for any consequences, which may arise as a result of its application.

# CONTENTS

---

**Householder:** Read the section 'About Your Solar Water Heater' (page 4 to 15). The 'Installation' section is intended for the installer but may be of interest.

ABOUT YOUR SOLAR WATER HEATER .....	4
Model Type .....	4
Pipe Work, Insulation & Freeze Protection .....	6
Turning On the Solar Water Heater .....	6
Shut Down Procedure .....	6
Temperature Adjustment .....	6
Other Important Information .....	7
Periodic Maintenance .....	8
Water Chemistry .....	11
Troubleshooting .....	12
Solar Monitor LED Indication .....	14
INSTALLATION .....	16
Installation Overview .....	16
Water Supplies .....	17
INSTALLATION – COMPONENTS .....	18
Solar Storage Cylinder Installation .....	18
Solar Controller Kit Installation .....	18
Solar Collector Kit Installation .....	19
INSTALLATION – PLUMBING & PLUMBING CONNECTIONS .....	21
Solar Storage Cylinder Plumbing & Plumbing Connections .....	21
Solar Controller Kit Plumbing & Plumbing Connections .....	23
Solar Collector Circuit Plumbing & Plumbing Connections .....	24
General Plumbing Arrangement & Plumbing Diagrams .....	27
Two Temperature Zones Using a Temperature Limiting Device .....	27
Circulated Hot Water Flow & Return Systems .....	27
INSTALLATION – ELECTRICAL & ELECTRICAL CONNECTIONS .....	29
Solar Control Unit Electrical & Electrical Connections .....	29
Electric Booster Electrical & Electrical Connections .....	29
Booster Thermostat Adjustment .....	29
COMMISSIONING .....	30
Pressure Testing .....	30
Pre Commissioning Procedure .....	30
To Fill, Turn ON and Commission the Solar Water Heater .....	30
Draining the Solar Collectors .....	32
Draining the Solar Storage Cylinder .....	32
Dimensions and Technical Data .....	34
WARRANTY .....	38

# ABOUT YOUR SOLAR WATER HEATER

---

## Product Application

This solar water heater is designed for use in a single family domestic dwelling for the purpose of heating potable water. Its use in an application other than this may shorten its life.

**⚠ Warning:** *This solar water heater is only intended to be operated by persons who have the experience or the knowledge and the capabilities to do so. This solar water heater is not intended to be operated by persons with reduced physical, sensory or mental capabilities i.e. the infirm, or by children. Children should be supervised to ensure they do not interfere with the solar water heater.*

## Model Type

---

Your Aquamax<sup>®</sup> solar water heater is designed for the solar collectors to be roof mounted and the vitreous enamel lined solar storage cylinder with integrated electric booster, installed at ground or floor level, remotely from the solar collectors. The system has 2 or 3 Aquamax S solar collectors. The number of collectors required will depend upon the installations region and collector location. For most installations, the number of solar collectors recommended in the Aquamax literature has been proven to provide the required solar energy to meet the average family needs. The solar storage cylinder is suitable for outdoor or indoor installation.

This solar water heater is designed to be installed as an electric boosted solar water heater with the electric booster heating circuit connected to a continuous tariff power supply. This solar water heater is not to be used as a pool heater.

The solar water heater has a level of freeze protection designed to guard the system against damage from freeze conditions. Freeze conditions occur below 6°C. The system must be installed with the full length of the solar hot and solar cold pipes insulated to offer protection against freeze damage (refer to 'Pipe Work Insulation & Freeze Protection' on page 6). The solar water heater has NO WARRANTY for freeze damage if the solar hot and solar cold pipes are not insulated in accordance with the installation instructions (refer to 'Terms of the Aquamax Warranty' on page 38). The solar water heater is not suitable for installation above 400 metres altitude and has NO WARRANTY for freeze damage if installed above 400 metres altitude.

This solar water heater is designed to be installed with an Aquamax solar controller kit AQ7014151.

Aquamax solar collectors have passed the AS/NZS 2712 requirements for resistance to hailstone damage, so it is not normally necessary to fit a guard to a collector. Stone Guards are available which provide a level of protection to the collectors against vandalism or accidental damage.

## Model Selection Chart

The model numbers shown below apply only to the solar storage cylinder.

415 Litre	325 Litre	260 Litre
SE415SM36	SE325SM36	SE260SM36
SE415SM48	SE325SM48	SE260SM48

**Note:** All models can be supplied with a 'Hard Water Anode'. These models have the suffix 'HWA' at the end of the model number.

### Legend

<b>SE</b>	Solar Electric (storage cylinder)
<b>415, 325, 260</b>	Storage cylinder capacity in litres
<b>SM36, SM48</b>	Single mid element 3600W and 4800W respectively

## Solar Operation

The Aquamax open circuit solar system has a vitreous enamel lined steel storage cylinder installed at ground or floor level, remotely located from the solar collectors.

The sun's energy heats the water in the solar collectors which increases in temperature. When the water in the solar collectors is hotter than the water in the solar storage cylinder, the circulator is activated. The circulator moves the water from the solar collectors, through an insulated copper pipe to the solar storage cylinder, whilst cooler water from the solar storage cylinder is circulated back to the solar collectors to be heated by the sun's energy.

This process continues while solar energy is available and until the water in the solar storage cylinder reaches a temperature of 70 ~ 80°C.

Automatic safety controls are fitted to the solar water heater to provide safe and efficient operation.

## Electric Booster Operation

The electric booster is an electric immersion heating unit (element) which is located behind the front access cover of the solar storage cylinder. Water stored in the solar storage cylinder is heated by the electric booster at times of low solar energy (low solar gain), such as during very cloudy or rainy weather, or during the colder months of the year.

The electric booster is controlled by an electric thermostat which has an integral protective over temperature energy cut out. The temperature of the water in the solar storage cylinder above the electric booster is automatically heated to and maintained at the thermostat setting when the electric booster is energised. The booster thermostat is also located behind the front access cover of the solar storage cylinder.

The electric booster will only operate if heating is required. When the water in the storage cylinder is below the booster thermostat setting, the electric booster will be automatically turned on. When the water in the storage cylinder reaches the booster thermostat setting, the electric booster will be automatically turned off. Also refer to 'Hot Water Temperature' on page 5.

The amount of water heated by the electric booster is as follows:

Model	SE415	SE325	SE260
Litres of water above electric booster	271.3L	206.5L	153.8L

## Mains Pressure Operation

This solar water heater is designed to operate at mains pressure by connecting directly to the mains water supply. If the mains water supply pressure in your area exceeds that shown in 'Mains Water Supply' on page 17, a pressure limiting valve must be fitted. The supply pressure should be greater than 350 kPa for true mains pressure operation to be achieved. A minimum water supply pressure of 200 kPa is required to enable the solar circulator and solar circuit system to operate effectively.

## Hot Water Temperature

The solar control unit will circulate water through the solar collectors until a temperature of 70 ~ 80°C is reached in the solar storage cylinder. During periods of low solar energy gain, the water temperature in the solar storage cylinder will be automatically boosted by the thermostatically controlled electric booster to a factory setting of 60°C.

The booster thermostat temperature setting is adjustable from 60 ~ 70°C (refer to 'Temperature Adjustment' on page 6).

**⚠ Warning:** *Booster thermostat temperature adjustment must only be performed by an electrician or qualified person.*

## High Hot Water Temperature Increases the Risk of Scald Injury

**⚠ Warning:** *This solar water heater can deliver water at temperatures which can cause scalding. Always check the water temperature before use, such as when entering a shower or filling a bath or basin, to ensure it is suitable for the application and will not cause scald injury. Aquamax recommends monthly temperature checks to ensure the appropriate temperature is maintained within the solar water heater.*

Aquamax recommends, and it may also be required by regulations, that a secondary device such as an approved temperature limiting device or anti-scald water shut off valve be fitted into the hot water pipe work to the bathroom and ensuite(s) if persons living in the house require additional safety protection from potential scalding. This will keep the hot water supply temperature to the bathroom(s) and ensuite(s) below 50°C which will reduce the risk of scald injury whilst still allowing hotter water (60°C+) to the kitchen and laundry.

For new hot water installations, all sanitary outlet fixtures used primarily for personal hygiene purpose must deliver hot water not exceeding 50°C. This temperature limit is not mandatory for kitchen sinks and laundry tubs.

To minimise scalding, especially for those people in high scald risk categories i.e. young children, people with potentially incapacitating medical conditions, elderly people etc, this solar water heater must be installed in accordance with AS/NZS 3500.4.

This appliance is not intended for use by persons (including children) with reduced physical, sensory or mental capabilities, or lack of experience and knowledge, unless they have been given supervision or instruction concerning use of the appliance by a person responsible for their safety.

Children should be supervised to ensure that they do not play with the appliance.

For early childhood centres, primary and secondary schools, nursing homes or similar facilities for young, aged, sick or disabled persons, please consult your local health authority for the correct temperature setting.

### **Pipe Work, Insulation & Freeze Protection**

---

The solar hot and solar cold pipe work between the solar storage cylinder and the solar collectors and the pipe work between this solar water heater and a temperature limiting device, or this solar water heater and a hot water outlet if a temperature limiting device is not installed **MUST BE** of copper. Plastic pipe **MUST NOT** be used, as it will not withstand the temperature and pressure of the water generated by the solar collectors under certain conditions. All compression fittings must use brass or copper olives.

The system has a level of freeze protection designed to guard the system against damage from freeze conditions. Freeze conditions occur below 6°C. The full length of the solar hot and solar cold pipes **MUST BE** insulated in accordance with these installation instructions.

The system has NO WARRANTY for freeze damage when installed above 400 metres altitude or if the solar hot and solar cold pipes are not insulated in accordance with the installation instructions (refer to 'Terms of the Aquamax Warranty' on page 38).

The anti freeze control is designed to recirculate a small amount of water from the solar storage cylinder through the solar pipe work and solar collectors during periods of low temperatures. This is to prevent the water inside the pipe work and collectors from freezing.

It is essential the electrical circuit to the solar control unit is continually turned on if there is a risk of freezing. The Aquamax warranty does not cover damage caused by freeze conditions when the electrical circuit or electrical supply to the solar control unit is turned off or interrupted.

**⚠ Warning:** *If it is necessary to switch the power off to the solar control unit and there is a risk of freezing, then it is necessary to have your plumber drain the solar collectors and solar flow and return pipe work.*

### **Turning On the Solar Water Heater**

---

To turn on the solar water heater:

1. Fully open the cold water isolation valve at the cold water inlet to the solar storage cylinder.
2. If maintenance has been conducted on the solar collectors or solar pipe work and air has entered the system, or if the collectors and solar hot and solar cold pipes have been drained, it will be necessary to purge the collector circuit of air which would otherwise prevent the solar water heater from operating (refer to 'Purging the Solar Collectors' on page 10). **Note:** Air trapped in the system can prevent solar gain from occurring and cause the system to operate on the electric booster only.
3. Switch on the electrical supply at the power outlet to the solar control unit. **Note:** The power outlet must be switched on for the solar control unit to operate and for solar gain to be achieved. The solar control unit also provides additional freeze protection when energised.
4. Switch on the circuit breaker or isolator marked 'Hot Water' or 'Water Heater' at the switchboard. This will turn on the electric booster circuit.

### **Shut Down Procedure**

---

If it is necessary to turn off the solar water heater:

1. Switch off the circuit breaker or isolator marked 'Hot Water' or 'Water Heater' at the switchboard. This will turn off the electric booster circuit.
2. Switch off the electrical supply at the power outlet to the solar control unit. **Note:** The Aquamax warranty does not cover damage caused by freeze conditions when the electrical circuit or electrical supply to the solar control unit is turned off or interrupted. If there is a risk of freezing conditions, then it is necessary to drain the solar collectors and solar flow and return pipe work (refer to 'Pipe Work, Insulation & Freeze Protection' on page 6).
3. Close the cold water isolation valve at the cold water inlet to the solar storage cylinder.

### **Temperature Adjustment**

---

The solar control unit will circulate water through the solar collectors until a temperature of 70 ~ 80°C is reached in the solar storage cylinder. This temperature setting is non adjustable.

During periods of low solar energy gain, the water temperature in the solar storage cylinder will be automatically boosted by the thermostatically controlled electric booster (refer to 'Electric Booster Operation' on page 5). The booster thermostat setting can be set by a qualified person to a minimum of 60°C and a maximum of 70°C; however Aquamax recommends that the booster thermostat is set at 60°C to maximise solar contribution (the booster thermostat has a factory setting of 60°C).

AS 3498 requires that a water heater provides the means to inhibit the growth of Legionella bacteria in potable water. As this solar water heater is installed with an integral electric booster, then this requirement can be satisfied provided the electric booster thermostat setting is set at 60°C or higher and power is available to the electric booster circuit.

**⚠ Warning:** *The thermostat and its protective over temperature cut out are mounted behind the front access cover of the solar storage cylinder. The removal of the front access cover will expose 240V wiring. Access covers must only be removed by an electrician or qualified person.*

**⚠ Warning:** *Booster thermostat temperature adjustment must only be performed by an electrician or qualified person.*

## Other Important Information

---

### Going Away?

If you plan to be away from home for one or two nights, we suggest you leave the solar water heater switched on. However, if you plan to stay away more than a few nights, conserve energy by switching the electric booster circuit off at the switchboard. It is not necessary to switch off the electrical supply to the solar control unit.

If the system is not to be used for a period in excess of 2 weeks it is recommended that the solar collectors be covered.

If it is necessary to turn off the solar water heater for any reason, follow the 'Shut Down Procedure' on page 6.

**Note:** When switched back on, the solar water heater will take some time to reheat the water by solar gain. The time to reheat the water in the solar storage cylinder will depend upon time of year, time of day and prevailing weather conditions; however, the electric booster will provide a quantity of hot water after a period of 2 ~ 6 hours (boost quantity and time dependent upon solar storage cylinder size).

### Safety

This solar water heater is supplied with temperature sensors, a thermostat, an over temperature and energy cut out and a combination pressure temperature relief valve. These devices must not be tampered with or removed. The solar water heater must not be operated unless each of these devices are fitted and are in working order.

The Aquamax warranty may not cover faults if relief valves or other safety devices are tampered with or if the installation is not in accordance with these instructions.

**⚠ Warning:** *For continued safety of this solar water heater, all components must be installed, operated and maintained in accordance with all Owner's Guides and Installation Instructions supplied with the solar water heater. These instructions must be read in conjunction with all other instructions affixed to the appliance.*

**⚠ Warning:** *This solar water heater uses 240 V AC electrical power for operation of the solar control unit and electric booster. The removal of the solar control unit or electric booster cover will expose 240 V wiring. Covers must only be removed by a qualified person.*

**⚠ Warning:** *The solar control unit power lead must be plugged into a weatherproof electrical outlet if installed outdoors. Take care not to touch the power plug with wet hands.*

**⚠ Warning:** *Care should be taken not to touch the pipe work connecting the solar storage cylinder and the solar collectors. Very high temperature hot water can be generated by the solar collectors under certain conditions and pipe work from the solar collectors to the solar storage cylinder can become very hot.*

**⚠ Warning:** *If the power supply cord or plug to the solar control unit is damaged, it must be replaced by a qualified person in order to avoid a hazard. The power supply cord and plug must be replaced with a genuine replacement part available from Aquamax. Phone Aquamax Service or their nearest Accredited Service Agent to arrange for an inspection or service.*



## How Long Will the Water Heater Last?

The solar water heater is supported by a manufacturer's warranty (refer to page 38). There are a number of factors that will affect the length of service the solar water heater will provide. These include but are not limited to the water chemistry, the water pressure, the water temperature (inlet and outlet) and the water usage pattern.

## Precautions

Where damage to property can occur in the event of the solar water heater leaking, the solar water heater must be installed in a safe tray. Construction, installation and draining of a safe tray must comply with AS/NZS 3500.4 and all local codes and regulatory authority requirements.

The solar water heater must be maintained in accordance with the Owner's Guide and Installation Instructions. Refer to 'Periodic Maintenance' on page 8.

If this solar water heater is to be used where an uninterrupted hot water supply is necessary for your application or business, you should ensure that you have back up redundancy within the hot water system design. This should ensure the continuity of hot water supply in the event that this solar water heater was to become inoperable for any reason. We recommend you seek advice from your plumber or specifier about your needs and building back up redundancy into your hot water supply system.

## Periodic Maintenance

---

### Minor Six Monthly Maintenance

It is recommended minor maintenance be performed every six months by the dwelling occupant.

**⚠ Warning:** Exercise care when operating easing levers as water discharged from the solar water heater may be of a very high temperature.

Minor maintenance actions:

1. Operate easing lever on the pressure temperature relief valve (refer to 'Pressure Temperature Relief Valve' on page 9).
2. Operate easing lever on expansion control valve (if ECV fitted) (refer to 'Expansion Control Valve' on page 9).
3. If a safety tray is installed, check to ensure the safety tray drain pipe is not blocked.
4. Clean solar collector glass if required (refer to 'Cleaning the Solar Collector Glass' on page 9).

### Major Five Year Service

It is recommended a major five year service be conducted on the solar water heater.

Servicing must be performed by a qualified person. Phone Aquamax Service or their nearest Accredited Service Agent.

**Note:** The five year service and routine replacement of any components, such as the anode and relief valves, are not included in the Aquamax warranty. A charge will be made for this work.

Solar water heater major five year service actions:

1. Replace pressure temperature relief valve.
2. Inspect and flush expansion control valve (if fitted) and replace expansion control valve if required.
3. Inspect and if required, replace the anode. If the anode is not replaced, it should be replaced within three years of this service (refer to 'Anode' on page 9).
4. Check the electric booster element for excessive calcium build up or corrosion and replace if required.
5. Check the solar control unit for correct operation.
6. Clean solar collector glass if required (refer to 'Cleaning the Solar Collector Glass' on page 9).
7. Flush solar collectors (refer to 'Flushing the Solar Collectors' on page 10).
8. Visually check system for any potential problems.
9. Inspect all plumbing and electrical connections.
10. If a safety tray is installed, check to ensure the safety tray drain pipe is not blocked.

**Note:** When switched back on, the solar water will take some time to reheat the water by solar gain. The time to reheat the water in the solar storage cylinder will depend upon time of year, time of day and

prevailing weather conditions; however, the electric booster will provide a quantity of hot water after a period of 2 ~ 6 hours (boost quantity and time dependent upon solar storage cylinder size).

### Pressure Temperature Relief Valve (PTR Valve)

The PTR valve is near the top of the solar storage cylinder and is essential for safe operation. It is possible for the PTR valve to release a little water through the drain line during each heating period. This occurs as the water is heated and expands by approximately 1/50 of its volume.

Continuous leakage of water from the PTR valve and its drain line may indicate a problem with the water heater (refer to 'Pressure Temperature Relief Valve Running' on page 13).

**⚠ Warning:** *Never block the outlet of the PTR valve or its drain line for any reason.*

Operate the easing lever on the PTR valve once every six months. **It is very important you raise and lower the lever gently.**

**⚠ Warning:** *Exercise care when operating easing lever as water discharge from the solar water heater may be of a very high temperature.*

**⚠ Warning:** *Exercise care to avoid any splashing of water, as water discharged from the drain line will be hot. Stand clear of the drain line's point of discharge when operating the valve's lever.*

**⚠ Danger:** *Failure to perform this procedure may result in the solar storage cylinder failing, or under certain circumstances, exploding.*

If water does not flow freely from the drain line when the lever is lifted, then the solar water heater must be checked. Phone Aquamax Service or their nearest Accredited Service Agent to arrange for an inspection.

The pressure temperature relief valve should be replaced at intervals not exceeding 5 years, or more frequently in areas where there is a high incidence of water deposits (refer to 'Water Chemistry' on page 11).

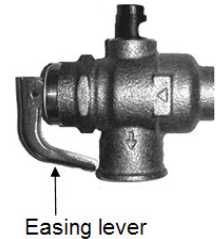

### Expansion Control Valve (ECV)

In many areas, including South Australia, Western Australia and scaling water areas, an ECV is fitted to the cold water supply line to the solar water heater (refer to the 'Cold Water Supply Plumbing Arrangement' diagram on page 22). The ECV may discharge a small quantity of water from its drain line during the heating period instead of the PTR valve on the solar water heater.

Operate the easing lever on the expansion control valve once every six months. **It is very important you raise and lower the lever gently.**

The expansion control valve should be checked for performance or replaced at intervals not exceeding 5 years, or more frequently in areas where there is a high incidence of water deposits (refer to 'Water Chemistry' on page 11).

### Anode

The anode installed in your solar water heater has been designed to slowly dissipate whilst protecting the solar storage cylinder. If the solar water heater is not used for two (2) weeks or more, a quantity of hydrogen gas, which is highly flammable, may accumulate in the solar water heater. To dissipate this gas safely, it is recommended that a hot tap be turned on for several minutes or until discharge of gas ceases. Use a sink, basin, or bath outlet, but not a dishwasher, clothes washer or other appliance. During this procedure, there must be no smoking, open flame, or any electrical appliances operating nearby. If hydrogen is discharged through the tap, it will probably make an unusual sound similar to air escaping.

The life of the solar storage cylinder may be extended by arranging a qualified person to periodically inspect the anode and replace if required. If the anode is not replaced during a five year service (refer to 'Major Five Year Service' on page 8) then the maximum time after installation when the anode should be replaced for this solar water heater is 8 years.

For water supplies which are either softened, desalinated or where the water supply may alternate between a water tank and a reticulated public supply or another supply, it is recommended the anode be replaced within 5 years of installation.

### Cleaning the Solar Collector Glass

Ensure the solar collector glass is free of dust, salt spray or any other matter which may reduce the effectiveness of the solar collectors. If the solar collector glass is dirty, the collectors can be hosed down with fresh water or, if the solar collectors are accessible, wash the collector glass with fresh water and a soft brush. Do not use cleaning agents. **Note:** The collector glass should only be hosed down or cleaned when the solar collectors are cool (early morning is the best time).

Have any trees trimmed which may shade the solar collectors.

## Flushing the Solar Collectors

It may be necessary to flush the solar collectors if there is sediment in the water supply. It is recommended that the solar collectors are flushed every five years. This will assist in keeping the solar collectors, solar cold pipe and solar hot pipe clear of sediment (refer to 'Major Five Year Service' on page 8). The following procedure should be performed in the morning, within three hours of sunrise, when the water temperature inside the solar collectors is lowest.

To flush the solar collectors:

1. Open a hot water tap and allow water to run for five (5) minutes prior to flushing solar collectors.
2. Close the hot tap.
3. Wait a further five (5) minutes before attempting to flush the solar collectors. This will assist in the transfer of any high temperature water in the solar collectors to the solar storage cylinder.
4. Using a flat bladed screwdriver, open the bleed valve located on the solar hot water inlet (from collector) of the solar storage cylinder (labelled 'Connection for Solar Return Pipe') by rotating the bleed valve screw (refer to diagram in the 'Purging the Solar Collectors' section on page 10). Mains pressure will force water to flow from the solar storage cylinder, through the pipe work and solar collectors, then out through the bleed valve thereby flushing the collectors. This is evidenced by water spurting from the drain line connected to the bleed valve. Allow water to flow from the bleed valve drain line for five (5) minutes.

**⚠ Warning:** Exercise care to avoid any splashing of water, as water discharged from the solar collectors may be of a very high temperature.

5. Using a flat bladed screwdriver, close the bleed valve.

## Purging the Solar Collectors

It is necessary to purge air from the solar collector circuit:

- After installation.
- When the solar system is to be turned on and the solar collectors and solar hot and solar cold pipes have been drained.
- After maintenance has been conducted on the solar collectors or pipe work and air has entered the system.
- If the circulator appears not to be circulating water around the system.

The following procedure should be performed in the morning, within three hours of sunrise, when the water temperature inside the solar collectors is lowest:

To purge air from the collector circuit:

1. Ensure solar storage cylinder is full of water and all premises hot taps are turned off.
2. Using a flat bladed screwdriver, rotate the bleed valve screw to the open position. The bleed valve is located on the solar hot water inlet (from collector) of the solar storage cylinder (labelled 'Connection for Solar Return Pipe'). Refer to diagram shown opposite.

Mains pressure will force water to flow from the solar storage cylinder, through the pipe work and solar collectors, expelling any trapped air from the collector circuit through the bleed valve. This is evidenced by water and air spurting from the drain line connected to the bleed valve.

**⚠ Warning:** Exercise care to avoid any splashing of water, as water discharged from the solar collectors may be of a very high temperature.

3. Using a flat bladed screwdriver, close bleed valve when all air has been purged by rotating bleed valve. **Note:** when air is purged water will run freely without spluttering.

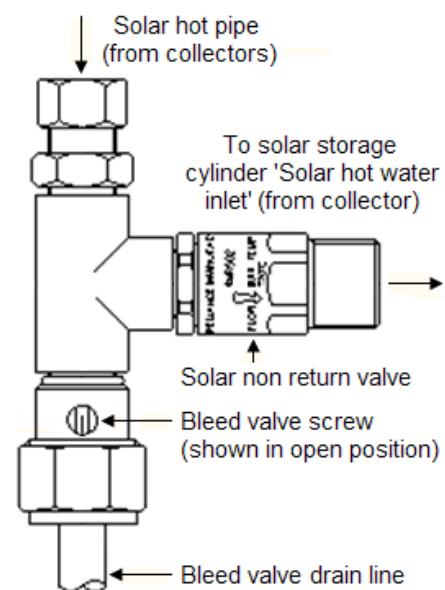

Note: This assembly is to be insulated by plumber

## Change of Water Supply

The changing or alternating from one water supply to another can have a detrimental effect on the operation and / or life expectation of the solar storage cylinder and pressure temperature relief valve.

Where there is a changeover from one water supply to another, e.g. a rainwater tank supply, bore water supply, desalinated water supply, public reticulated water supply or water brought in from another supply, then water chemistry information should be sought from the supplier or it should be tested to ensure the water supply meets the requirements given in these guidelines for the Aquamax warranty to apply.

## Water Chemistry

---

**This solar water heater must be installed in accordance with this advice to be covered by the Aquamax warranty.**

This solar water heater is manufactured to suit the water conditions of most public reticulated water supplies. However, there are some known water chemistries which can have detrimental effects on the solar water heater and its operation and / or life expectancy. If you are unsure of your water chemistry, you may be able to obtain information from your local water supply authority. This solar water heater should only be connected to a water supply which complies with these guidelines for the Aquamax warranty to apply.

### Total Dissolved Solids (TDS)

Some water analysis reports may state the conductivity of the water rather than the level of total dissolved solids. Conductivity, measured in microsiemens per centimetre ( $\mu\text{S} / \text{cm}$ ), is directly proportional to the TDS content of the water. TDS, in mg/L, is approximately 70% of the conductivity in  $\mu\text{S} / \text{cm}$ .

The Aquamax warranty will not cover resultant faults to the solar storage cylinder if this solar water heater is connected at anytime to a water supply where the TDS content of the water exceeds 600 mg/L. In locations where the water supply TDS exceeds 600 mg/Litre, the magnesium alloy anode (supplied as standard, cap colour code 'Black') should be replaced with an aluminium alloy anode (cap colour code 'Blue'). For more information refer to 'Water Chemistry & Anode Type' on page 11.

In locations where TDS approaches 600 mg/L, e.g. due to sediment, we strongly recommend fitting an appropriate filter to ensure water entering or in the solar water heater does not exceed this level at any time i.e. due to sediment build up.

### Water Chemistry & Anode Type

Aquamax solar water heaters are designed to suit the water conditions of most metropolitan supplies, where the Total Dissolved Solids (TDS) content of the supply is less than 600 mg/Litre. For use in regions where the water supply TDS exceeds 600 mg/Litre, the magnesium alloy anode (supplied as standard, cap colour code 'Black') may become excessively reactive. For safety reasons and the longevity of the anode, the magnesium anode should be replaced with an aluminium alloy anode (cap colour code 'Blue') available from your Aquamax supplier. Anode replacement must be carried out by an Aquamax accredited service agent.

**⚠ Warning:** *If the water supply has a TDS greater than 600 mg/L and the anode has not been changed to a blue anode, there is the possibility the anode may become overactive and hydrogen gas could accumulate in the top of the solar storage cylinder during long periods of no use.*

If the solar water heater has not been used for two or more weeks, follow the procedure detailed in the 'Anode' section on page 9 for safe dissipation of the hydrogen gas build up inside the solar storage cylinder.

It must be noted that in areas where the TDS exceeds 600 mg/Litre, the Aquamax warranty will not cover resultant faults on components including the solar storage cylinder that fail due to the bad water conditions even though an aluminium anode is fitted. Refer to 'Water Chemistry Levels Affecting Warranty' on page 11 for water chemistry levels and components affected.

The life of the solar water heater will also be extended by periodic inspection of the anode and replacement if necessary (refer to 'Periodic Maintenance' on page 8 and 'Anode' on page 9).

### Water Chemistry Levels Affecting Warranty

The Aquamax warranty of this solar water heater will not cover resultant faults on solar collectors if the water supply has a saturation index  $< -1.0$  or  $> 0.8$  (refer to 'Scaling Water & Saturation Index' on page 12).

The Aquamax warranty of this solar water heater will not cover resultant faults on components including the solar storage cylinder where water stored in the storage cylinder exceeds at any time any of the following levels:

Total dissolved solids	600 mg/Litre
Total hardness	200 mg/Litre
Chloride	300 mg/Litre
Magnesium	10 mg/Litre
pH	9.5 and not less than 6.5
Calcium	20 mg/Litre
Sodium	150 mg/Litre
Iron	1 mg/Litre

### Scaling Water & Saturation Index

The saturation index is used as a measure of water's corrosive or scaling properties.

In a corrosive water supply, water can attack copper parts and cause them to fail. Where the saturation index is less than  $-1.0$ , the water is very corrosive and the Aquamax warranty of this solar water heater will not cover resultant faults on a solar collector(s).

Where the saturation index exceeds  $+0.80$ , the water is very scaling and the Aquamax warranty of this solar water heater will not cover resultant faults on a solar collector(s).

Scaling water that contains levels of calcium carbonate (total hardness in excess of 200 mg/Litre at any time when the solar water heater is operating) can block and prevent the pressure & temperature relief valve from operating resulting in damage to the solar water heater storage cylinder and solar water heater components.

An expansion control valve is mandatory in SA & WA and must be fitted in ALL areas with scaling water to assist in preventing blockage of the pressure and temperature relief valve.

**⚠ Danger:** Failure to install an expansion control valve where scaling water conditions occur may result in the solar storage cylinder failing, or under certain circumstances, exploding.

To avoid damage to the solar storage cylinder and solar water heater components, Aquamax strongly recommends scaling water be treated before entering the solar water heater by fitting appropriate water filters/conditioners etc to reduce the saturation index and total hardness of the water. Refer to your Local Water Authority for information on water in your area. A build up of white sediment on hot water taps or shower roses can be indicative of scaling water. Contact Aquamax if this condition is observed.

### Spring, Dam, Bore & River Water Supplies

The Aquamax warranty of this solar water heater will not cover resultant faults on components including the solar storage cylinder due to the effects of sludge and/or sediment as a result of connection to a water supply from silted or treated sources i.e. springs, dams, bores, rivers or towns supplied from a bore.

### Troubleshooting

---

Check the items below before making a service call. You will be charged for attending to any condition or fault that is not related to manufacture or failure of a part. For warranty terms and conditions (refer to 'Warranty' on page 38).

#### Not Enough Hot Water (Or No Hot Water)

- Insufficient sunlight*

Insufficient sunlight due to cloudy weather during hotter months or low solar energy contribution in colder months may mean the electric booster operates more often.
- Is the solar water heaters electricity supply switched on?*

Check to ensure the solar control unit power supply cord is plugged in and the power outlet is switched on. Also check to ensure the circuit breaker or isolator marked 'Hot Water' or 'Water Heater' at the switchboard is turned on. If the switchboard has fuses, check to ensure the fuse marked 'Hot Water' or 'Water Heater' has not blown. Is power available in the house? Try using another electrical appliance.
- Solar Monitor green LED is off or red LED is flashing*

If the Solar Monitor green LED (marked 'SOLAR') is off, or the red LED (marked 'ATTENTION') is flashing, there may be a problem with the solar water heater operation and solar gain is not being achieved. This will result in the electric booster operating to provide all of the hot water required. Refer to 'Solar Monitor LED Indication' on page 14.



If the Solar Monitor green LED is off, or the red LED is flashing, switch off the electrical supply at the power outlet to the solar control unit for five (5) seconds and then switch back on again.

If the green LED remains off or the red LED recommences to flash, count the number of flashes and phone Aquamax Service or their nearest Accredited Service Agent to arrange for an inspection.

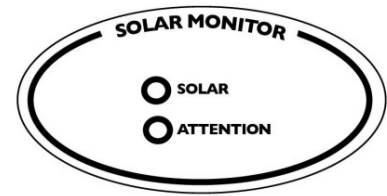

- *Solar Collectors shaded*

If trees or other objects shade the solar collectors or if the collector glass is dirty, the effectiveness of the solar collectors will be greatly reduced. Have the trees trimmed or the solar collectors relocated if the obstruction is permanent. Clean the collector glass if required (refer to 'Cleaning the Solar Collector Glass' on page 9).

- *Solar Collector area is too small*

For most installations, the number of solar collectors recommended in the Aquamax literature has been proven to provide the required solar energy to meet the average family needs. However, in some circumstances if two solar collectors have been installed, it may be necessary to install a third solar collector.

- *Air in collectors (no solar gain)*

It is possible under certain conditions, such as when the pipe work has been opened, that air may become trapped in the solar collectors. This will prevent the circulator from moving water around the solar collector circuit. The air will need to be purged from the solar collectors (refer to 'Purging the Solar Collectors' on page 10).

- *Are you using more hot water than you think?*

Is one outlet (especially the shower) using more hot water than you think? Very often the amount of hot water used is not realised, particularly when showering. Carefully review the family's hot water usage. As you have installed an energy saving Solar System, energy saving should also be practised in the home. Adjust your water usage pattern to take advantage of maximum solar gains. Have your plumber install a flow control valve to each shower outlet to reduce water usage.

- *Pressure temperature relief valve running*

Is the PTR valve discharging too much water? Refer to 'Pressure Temperature Relief Valve Running' on page 13.

- *Booster thermostat setting*

You may choose to have your electrician adjust the booster thermostat upwards to gain additional hot water capacity when boosting (refer to 'Temperature Adjustment' on page 6).

## **Pressure Temperature Relief Valve Running**

- *Normal Operation*

It is normal and desirable for the PTR valve to allow a small quantity of water to escape during the heating cycle, however there may be a problem if the valve continuously dribbles more than a bucket full of water in a normal 24 hour cycle.

- *Continuous dribble*

Try gently raising the easing lever on the relief valve for a few seconds (refer to 'Pressure Temperature Relief Valve' on page 9). This may dislodge a small particle of foreign matter and clear the fault. Release the lever gently.

- *Steady flows for long periods (often at night)*

This may indicate the mains water pressure sometimes rises above the designed pressure of the solar water heater. Ask your installing plumber to fit a pressure limiting valve.

**⚠ Warning:** *Never use reconditioned relief valves and never replace the relief valve with one of a higher pressure rating.*

- *Heavy flows of hot water until the solar water heater is cold - then stops until water reheats*

The solar control unit **must** be switched off at the power outlet. Phone Aquamax Service or their nearest Accredited Service Agent to arrange for an inspection.

## Expansion Control Valve Running

If an expansion control valve is fitted in the cold water line to the solar water heater, it may discharge a small quantity of water instead of the solar water heaters pressure temperature relief valve. This has the benefit of conserving energy as the discharged water is cooler (refer to the 'Cold Water Supply Plumbing Arrangement' diagram on page 22 for expansion control valve location).

## Electric Booster Operating Too Frequently

You may find that the electric booster operates more frequently than expected. This will occur when the solar heated water temperature is lower than the temperature setting of the booster thermostat. This may be experienced during periods of low solar energy gain or if there has been heavy hot water usage.

## Collector Glass Breakage

The Aquamax warranty **DOES NOT** cover breakage of solar collector glass. Check to ensure your household insurance policy covers solar collector glass breakage.

**⚠ Warning:** *No attempt should be made to remove or replace broken solar collector glass.*

The solar collector glass is not available as a replacement part. Contact Aquamax Service or their nearest Accredited Service Agent if the solar collector requires replacement.

## Noise from the Solar Collectors

This solar water heater has high performance selective surface solar collectors. When the solar storage cylinder is full of hot water, the circulator will turn off. The water in the solar collectors will continue to gain heat and increase in pressure when solar energy is still available.

When a hot tap is opened, this pressure is released and the high temperature water may turn to steam creating a sudden and loud rumbling noise and even a rattling or banging noise of the collectors against the roof cladding material. This results from the combination of the high level of solar radiation and the water in the solar storage cylinder being at its maximum temperature and is not caused by a fault with the solar water heater.

## Higher Than Expected Electricity Bills

With the installation of your new solar water heater, maximum energy savings can be achieved with careful planning of hot water usage. Check the following points if your electricity bill is higher than expected:

- *Is the relief valve running excessively?*  
Refer to 'Pressure Temperature Relief Valve Running' on page 13).
- *Is one outlet (especially the shower) using more hot water than you think?*  
Refer to 'Not Enough Hot Water' on page 12.
- *Is there a leaking hot water pipe, dripping hot water tap, etc?*  
Even a small leak will waste a surprising quantity of hot water and energy. Replace faulty tap washers and have your plumber rectify any leaks.
- *Is the booster operating too frequently?*  
Refer to 'Electric Booster Operating Too Frequently' on page 14.
- *Has there been an increase in hot water usage?*  
An increase in hot water usage may result in an increase in electric booster operation.
- *Has your tariff rate been increased by your energy retailer since your previous account?*  
Check your previous bill and compare electricity rates and charges.

**If you have checked all the previous troubleshooting points and still believe you need assistance, phone Aquamax Service or their nearest Accredited Service Agent.**

## Solar Monitor LED Indication

---

A solar monitor is located on the side of the solar control unit and houses a green and a red LED (refer to 'Solar Controller Major Kit Components' diagram on page 18 for solar control unit location).

The green LED, marked 'SOLAR', indicates the current operational mode of the solar water heater and the red LED, marked 'ATTENTION', indicates a fault mode.

The green LED will emit either a constant glow or a series of flashes, with a 2 second interval between each series.

The red LED will emit a series of flashes, with a 2 second interval between each series, only if there is a particular fault condition with the system.

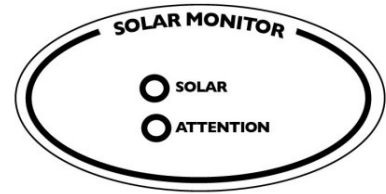

**Diagnostic Features of the Solar Control Unit**

Flashes	Operational Mode
Solid green (remains on)	Standby mode
Green slow pulse	Standby mode (power on for less than 48 hours)
Green rapid pulse	Circulating water through collectors
3 x green	Circulating water through collectors (system power on for less than 48 hours)
no green (remains off)	Power outage or call service

Flashes	Fault Mode
Solid red (remains on)	Hot sensor temperature greater than 130°C
Red rapid pulse	Temperature rise across collectors greater than 40°C (circulator at full speed)
3 x red	Hot sensor in collector – short circuit
4 x red	Hot sensor in collector – open circuit
5 x red	Cold sensor –short circuit
6 x red	Cold sensor – open circuit

If the power supply to the solar control unit is on and the green LED is off or the red LED is flashing, this indicates there may be a fault with the solar water heater. The red LED may emit up to six flashes in each series of flashes.

**Notes:**

- If the system is in standby mode with the green LED emitting either a constant glow or slow pulsing flashes (circulator is off) and the solar storage cylinder is full of hot water, the red LED may simultaneously emit a constant glow if solar radiation is still being received by the solar collectors. This does not indicate a fault. The red LED will go out when the temperature in the solar collectors decreases.
- During periods of high solar radiation and the circulator activates after having been off (green LED will emit either a rapid pulse or a series of 3 flashes), it is possible for the red LED to simultaneously emit a rapid pulse for a period of up to ten (10) minutes. This does not indicate a fault. If the red LED continues to emit a rapid pulse for longer than ten (10) minutes, or emits a series of flashes, count the number of flashes and phone Aquamax or an Accredited Service Agent to arrange for an inspection.



# INSTALLATION

---

## Installation Overview

---

This solar water heater must be installed by a qualified person in accordance with the installation instructions. The installation must comply with the requirements of AS/NZS 3500.4, AS/NZS 3000 and all local codes and regulatory authority requirements.

This solar water heater is comprised of the following components:

- Solar storage cylinder with integral electric booster.
- Solar controller kit.
- Solar collector kit.

This solar water heater is designed to be installed as an electric boosted solar water heater with the electric booster heating circuit connected to a continuous tariff power supply. The solar storage cylinder is suitable for outdoor or indoor installation.

The system is suitable for installation with two or three Aquamax S solar collectors. The number of collectors required will depend upon the installations region and collector location (contact Aquamax for more information). For most installations, the number of solar collectors recommended in the Aquamax literature has been proven to provide the required solar energy to meet the average family needs. The solar water heater is not suitable for installation above 400 metres altitude.

This solar water heater is not suitable for pool heating.

## Important Notes

- Working on roofs is and should always be considered a hazardous activity, particularly early in the morning and late in the evening, when the roof is wet and during and after periods of rain.
- All work must be carried out in accordance with Local, State and Federal Occupational Safety, Health and Welfare Regulations. Safety requirements whilst manual lifting, working at heights and on roofs must be adhered to.
- Installers must be competently trained in:
  - Height Hazard Assessment.
  - Working at Height Procedures.
  - Assessment / Use / Wearing of correct height safety equipment (harnesses etc.).
  - All other relevant safety factors specific to the installation and maintenance work to be compliant with suitable Occupational, Health and Safety Regulations / Codes.
- All relevant permits shall be obtained from the regulatory authorities before commencing work to install the solar water heater.
- All work carried out must be performed by appropriately qualified tradespeople or be suitably supervised for trades assistant duties.
- Every care must be taken to protect and warn occupants of the building and the public from personal injury which may occur from falling tools, roof materials, fittings or any other hazards of a general nature.
- Advise the occupants of any inconvenience which may occur due to disconnection of existing water and electrical supplies.
- The connection, attachment, integration or general association of other equipment or parts which either directly or indirectly affect the operation or performance of this equipment could void the Aquamax warranty.

## Freeze Protection

The solar water has a level of freeze protection designed to guard the system against damage from freeze conditions. Freeze conditions occur below 6°C. The full length of the solar hot and solar cold pipes **MUST BE** insulated in accordance with these installation instructions (refer to 'Warning: Important Notes for Plumber' on page 26). The solar water heater has NO WARRANTY for freeze damage when installed above 400 metres altitude or if the solar hot and solar cold pipes are not insulated in accordance with the installation instructions (refer to 'Terms of the Aquamax Warranty' on page 38).

## Hot Water Redundancy

If this solar water heater is to be used where an uninterrupted hot water supply is necessary for the application or business, then there should be redundancy within the hot water system design. This should ensure the continuity of hot water supply in the event that this solar water heater was to become inoperable for any reason. We recommend you provide advice to the solar water heater owner about their needs and building backup redundancy into the hot water supply system.

## Water Supplies

---

### Mains Water Supply

Where the mains water supply pressure exceeds that shown in the table below, an approved pressure limiting valve is required and should be fitted after the stop cock and before the non return valve as shown in the 'Cold Water Supply Plumbing Arrangement' diagram on page 22.

Model		SE260, SE325 & SE415
Pressure temperature relief valve setting		1000 kPa
Expansion control valve (ECV) setting *		850 kPa
Minimum mains supply pressure		200 kPa
Maximum mains supply pressure	With ECV	680 kPa
	Without ECV	800 kPa

\* Expansion control valve not supplied with water heater.

### Tank Water Supply

If the solar water heater is supplied with water from a tank supply and a pressure pump system is not installed, then the bottom of the supply tank must be at least 1 m above the highest point of the premises hot water plumbing system, including the solar storage cylinder. Care must be taken to avoid air locks. The cold water supply line to the solar water heater must be adequately sized and fitted with an approved full flow gate valve or ball valve and non return valve.

If the solar water heater is supplied with water from a tank supply and a minimum water supply pressure of 200 kPa at the solar storage cylinder inlet cannot be achieved, then a pressure pump system must be installed to ensure the minimum mains supply pressure is provided and maintained. Care must be taken to avoid air locks. The cold water line from the supply tank should be adequately sized and fitted with an approved full flow gate valve or ball valve and non return valve.

### Water Supply Chemistry

Bad water can have a detrimental effect on solar water heater operation, components and life expectancy and may affect warranty. Refer to 'Water Chemistry' on page 11 for more information. Also refer to 'Spring, Dam, Bore & River Water Supplies' on page 12.

## INSTALLATION – COMPONENTS

---

This section details the installation of the solar storage cylinder, solar controller kit and solar collector kit. To install the plumbing for these components refer to the 'Installation – Plumbing & Plumbing Connections' section on page 21.

### Solar Storage Cylinder Installation

---

#### Solar Storage Cylinder Location

The solar storage cylinder is suitable for either outdoor or indoor installation. The solar storage cylinder should be installed close to the most frequently used outlet and its position chosen with safety and service in mind.

Consideration must also be given to the position of the solar storage cylinder in relation to the solar collectors. There are limitations to both the maximum length of the solar hot and solar cold pipes (refer to 'Solar Pipe Lengths' on page 24) and the maximum height between the solar storage cylinder and the solar collectors (refer to 'Maximum Height to Collectors' on page 24).

Sufficient and safe space for ease of service and access to the electrical access cover, solar control unit, sacrificial anode and relief valve should be considered when locating the solar storage cylinder. The solar storage cylinder must be installed upright in a vertical position and must be accessible without the use of a ladder or scaffold.

You must be able to read the information on the rating plate. If possible leave headroom of one solar storage cylinder height so the anode can be inspected and / or replaced. If adequate room is unavailable, the solar storage cylinder must be disconnected, drained and removed to enable servicing.

It is recommended the solar storage cylinder be installed at ground or floor level and must stand vertically upright. It is not necessary to allow for free air circulation under the base of the solar storage cylinder. For outdoor installation, the solar storage cylinder shall be installed freestanding on a level and stable concrete base 50mm thick.

All packaging materials must be removed from the solar storage cylinder prior to installation. This includes the removal of the cardboard base of the carton from the underside of the solar storage cylinder.

Do not install this solar storage cylinder in a roof space.

**Note:** Damage to the storage cylinder caused by incorrect installation is not covered by warranty.

#### Safe Tray

Where damage to property can occur in the event of the solar storage cylinder leaking, the solar storage cylinder must be installed in a safe tray. Construction, installation and draining of a safe tray must comply with AS/NZS 3500.4 and all local codes and regulatory authority requirements. AS/NZS 3500.4 also has particular requirements when a safe tray must be installed.

### Solar Controller Kit Installation

---

The solar controller kit contains a bleed valve / non return valve assembly and a solar control unit with circulator, 4 way tee, preformed pipe piece and cold sensor probe. The kit also contains two insulation pieces, installation instructions and various kit connecting components.

The bleed valve / non return valve assembly is fitted to the solar storage cylinder outlet marked 'Connection for Solar Return Pipe' and is utilised when flushing or purging air from the collector circuit (refer to 'Flushing the Solar Collectors' on page 10 and 'Purging the Solar Collectors' on page 10).

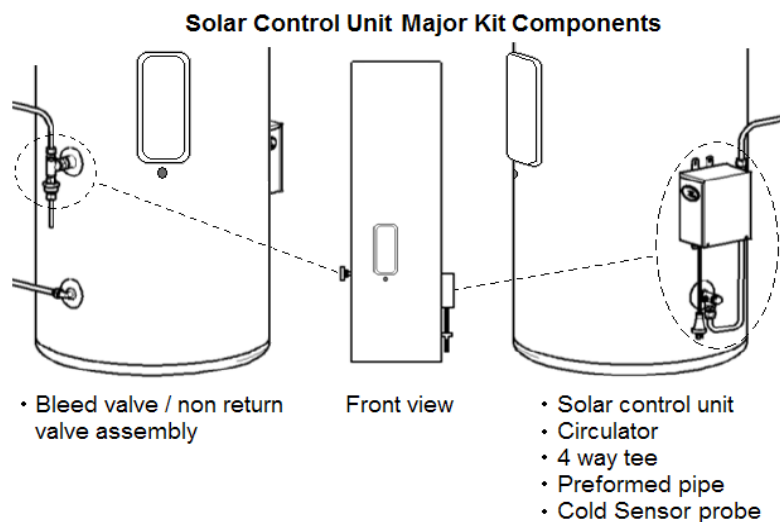

The solar control unit is mounted on the side of the solar storage cylinder and controls system operation. The solar control unit has a power cord which connects to a 240 volt general purpose outlet (refer to 'Installation – Electrical & Electrical Connections' on page 29).

The solar control unit incorporates a circulating pump which when energised circulates water from the solar storage cylinder through the collector circuit and back to the solar storage cylinder.

Refer to the installation instructions supplied with the solar controller kit for details on the installation and plumbing of the solar controller kit.

## Solar Collector Kit Installation

### Solar Collector Location

Consideration must be given to the position of the solar collectors in relation to the solar storage cylinder. There are limitations to both the maximum length of the solar hot and solar cold pipes (refer to 'Solar Pipe Lengths' on page 24) and the maximum height between the solar storage cylinder and the solar collectors (refer to 'Maximum Height to Collectors' on page 24).

Solar collectors must be installed in a shade free position.

The surrounding vicinity should be checked for higher buildings or trees which may cause shade at other times of the year and for small trees which may grow and shade the solar collectors in the future.

For optimum performance, solar collectors should be installed facing towards the equator (i.e. north facing in the southern hemisphere). ALWAYS CHECK ORIENTATION WITH A COMPASS. Where this orientation is not practical, solar collectors facing 45° from the equator will receive approximately 4% less total solar radiation.

For optimum performance, inclination of solar collectors should be approximately equal to 90° of the local latitude angle. The latitudes of some Australian cities are shown in the 'Latitude of Some Australian Cities Table' on page 20. Solar collectors may be installed at the roof angle for simplicity of installation and appearance, but must never be flat. If the roof angle varies by 15° from the optimum angle, the solar collectors will receive approximately 10% less total solar radiation.

The collector kit is suitable for installations with an inclination of up to 45°. Where the solar collectors are installed at inclinations greater than 45°, a With Pitch frame is necessary. Refer to your local Solar Distributor for details.

For a solar collector installation on a roof with a pitch less than 10°, a Variable Pitch frame is required. Refer to your local Solar Distributor for details.

For an installation of collectors on a pitched roof in a cyclonic or high wind area, a suitable With Pitch frame is required. Refer to your local Solar Distributor for details.

The installation of Aquamax S solar collectors on a suitable frame, subject to the frame's design criteria not being exceeded:

- is suitable for installation in geographic locations up to and within Wind Region D (With Pitch frame) or up to and within Wind Region C (Variable Pitch frame), as defined in the Building Code of Australia, Australian / New Zealand Standard AS/NZS 1170.2:2002 and the Australian Standard AS 4055-2006, and
- provides an acceptable method of installation where it is necessary to satisfy the requirements of the Building Code of Australia and AS/NZS 3500.4 Clause 6.5.3.4 for high wind areas.

The installer must ensure the structural integrity of the building is not compromised by the solar water heater installation and the roof structure is suitable to carry the full weight of the solar collector(s). If in doubt the roof structure should be suitably strengthened. Consult a structural engineer.

Each solar collector and its fittings weighs approximately 45 kg when full of water.

The installation must comply with the requirements of AS/NZS 3500.4 and all local codes and regulatory authority requirements.

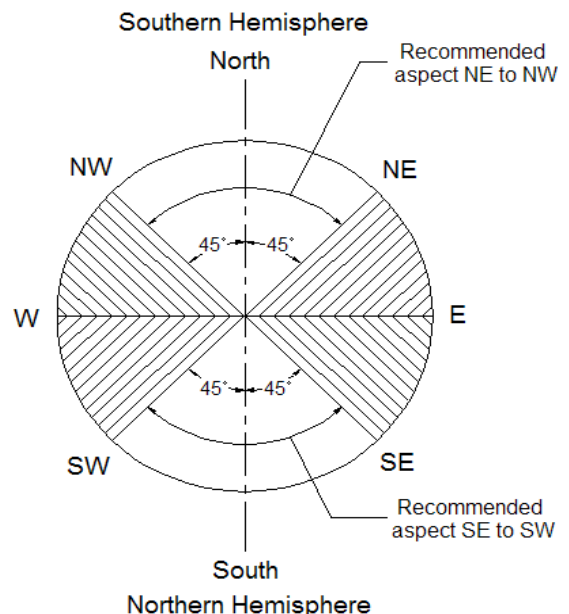

Latitude of Some Australian Cities							
Adelaide	35°S	Cairns	17°S	Hobart	42°S	Port Hedland	20°S
Alice Springs	24°S	Canberra	35°S	Mildura	34°S	Rockhampton	24°S
Brisbane	27°S	Darwin	12°S	Melbourne	38°S	Sydney	34°S
Broken Hill	31°S	Geraldton	28°S	Perth	32°S	Townsville	19°S

Refer to the installation instructions supplied with the solar collector kit for details on the installation of the solar collector kit.

Refer to 'Solar Collector Circuit Plumbing & Plumbing Connections' on page 24 for information on plumbing the solar collector circuit.

**⚠ Warning:** For installation requirements critical for correct operation of the solar water heater, refer to 'Warning: Important Notes for Plumber' on page 26.

## INSTALLATION – PLUMBING & PLUMBING CONNECTIONS

This section details plumbing, plumbing connections and plumbing diagrams for the solar storage cylinder, solar controller kit and solar collector kit. To install these components refer to the 'Installation – Components' section on page 18.

### Solar Storage Cylinder Plumbing & Plumbing Connections

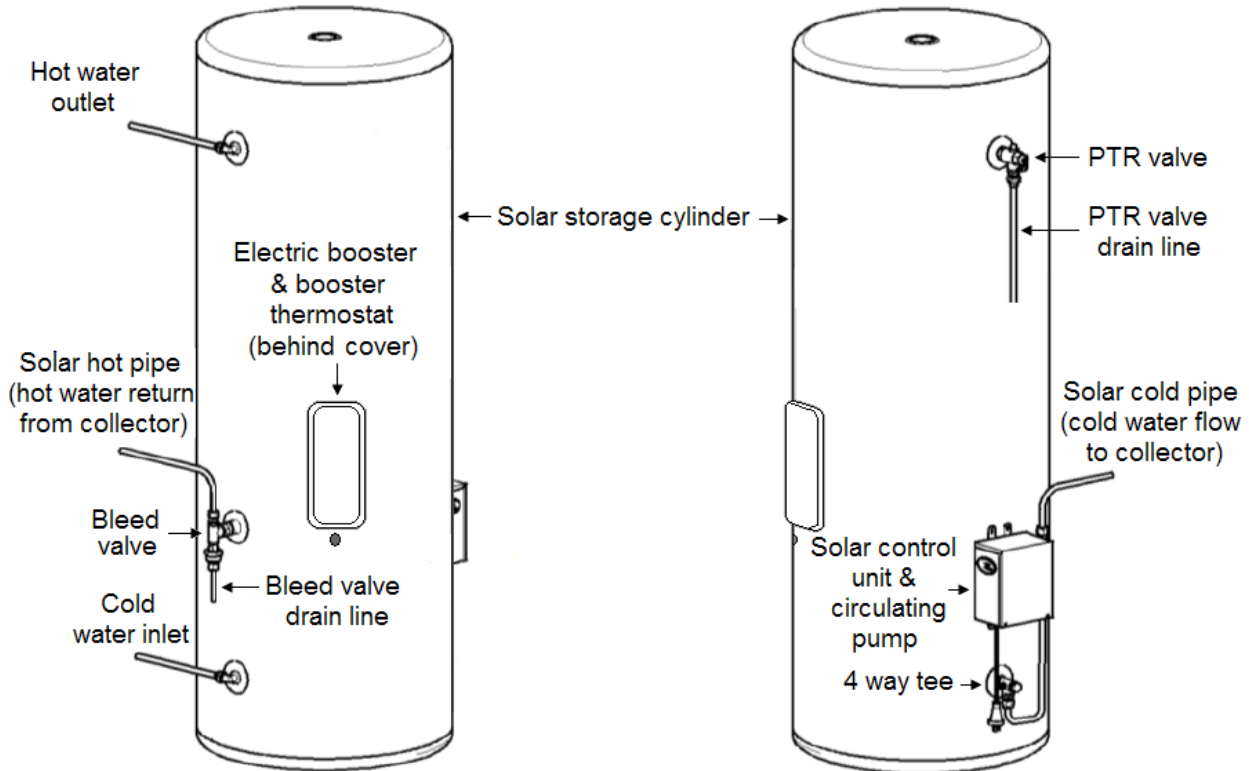

**⚠ Warning:** The pipe work between this solar water heater and a temperature limiting device, or this solar water heater and a hot water outlet if a temperature limiting device is not installed **MUST BE** of copper. Plastic pipe **MUST NOT** be used. All compression fittings must use brass or copper olives.

This solar water heater can produce water at a temperature and pressure which can exceed the performance limits of plastic pipe. This may result in pipe failure leading to severe water damage to the property. If plastic pipe is used as a hot water pipe in the property, then a temperature limiting device must be installed between the solar water heater and the plastic pipe work.

All pipe work must be cleared of foreign matter before connection and purged before attempting to operate the solar water heater. All olive compression fittings must use brass or copper olives. Use thread sealing tape or approved thread sealant on all other fittings (never use hemp).

A disconnection union must always be provided at the cold water inlet, solar cold water outlet, solar hot water inlet and hot water outlet of the solar storage cylinder to allow for solar water heater disconnection.

All Aquamax storage cylinder water fittings have a plastic liner fitted. These liners must be in place for the solar water heater to function properly. All liners are correctly positioned during manufacture and should not require handling during installation, however if a liner is not correctly inserted or aligned, it should be gently pushed back into place before connecting any plumbing fittings.

**⚠ Warning:** Plastic liners must be in place for the solar water heater to function properly. Do not remove or damage liners.

**⚠ Warning:** Do not use heat near plastic liners. Heat can be transferred by conduction which may damage liners.

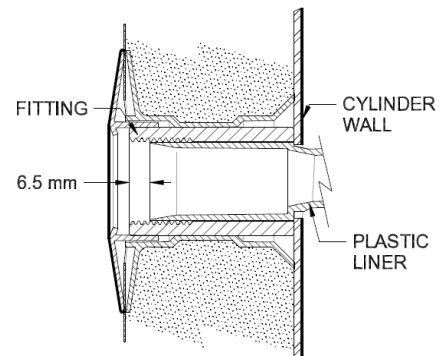

#### Solar Storage Cylinder Cold Water Inlet Connection

An approved isolation valve and non return valve must be installed in the cold water supply line to the solar storage cylinder. A non return valve must be fitted on the cold water supply to the solar storage cylinder in

compliance with Clause 5.9.1 of AS/NZS 3500.4. Due to the high temperatures generated by solar water heaters, an additional effective back-flow prevention device also should be fitted as an extra safeguard. Valve manufacturer RMC recommends Dual Check Valve No N7150, as being suitable for this application.

A pressure limiting valve and expansion control valve may also be required (for PLV requirements refer to 'Water Supplies' on page 17 and for ECV requirements refer to 'Expansion Control Valve' on page 22).

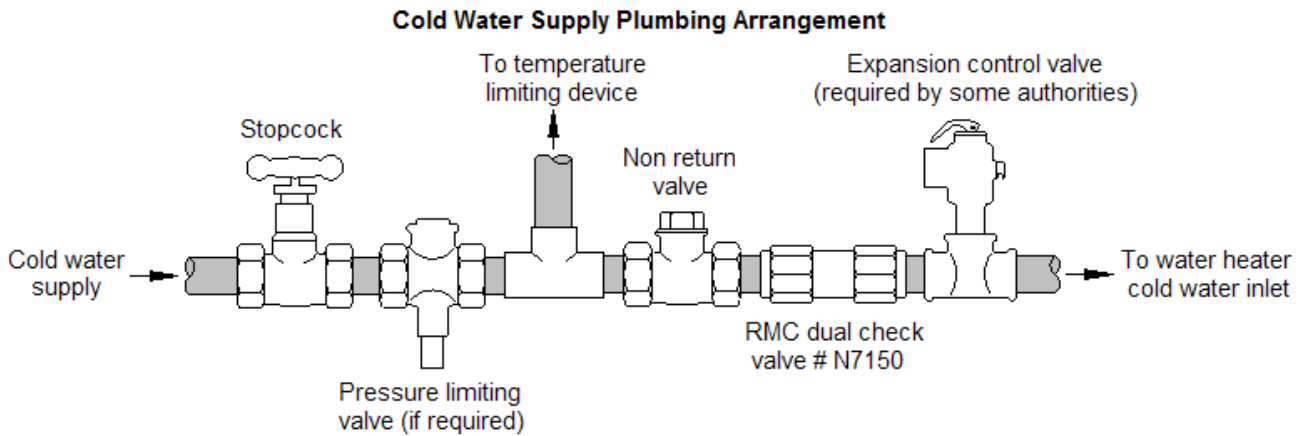

For detailed system plumbing diagrams refer to the 'General Plumbing Arrangement & Plumbing Diagrams' section starting on page 27.

### Expansion Control Valve

In some areas, local regulations may make it mandatory to install an expansion control valve (ECV) in the cold water line to the solar water heater. Refer to 'Scaling Water & Saturation Index' on page 12.

The ECV must always be installed after the combination non return isolation valve and be the last valve installed prior to the solar water heater (refer to the 'Cold Water Supply Plumbing Arrangement' diagram on page 22). A copper drain line must be fitted to the ECV (refer to 'Relief Valve Drain(s)' on page 23).

The ECV must be insulated with closed cell polymer insulation or similar (minimum thickness 9 mm) and the insulation installed so as not to impede the operation of the valve. The insulation must be weatherproof and UV resistant if exposed.

### Pressure Temperature Relief Valve

The pressure temperature relief (PTR) valve must be fitted before the solar water heater is operated. Before fitting the PTR valve, make sure the valve probe has not been bent. Seal the valve thread with thread sealing tape (never use hemp) and ensure the tape does not protrude past the end of the thread.

Screw the valve clockwise into the right hand side opening on the solar storage cylinder marked 'PTR' with the valve outlet pointing downwards (refer to 'Solar Storage Cylinder Plumbing and Plumbing Connections' diagram on page 21). Do not use a wrench on the valve body – use a spanner on the spanner flats.

A copper drain line must be fitted to the PTR valve (refer to 'Relief Valve Drain(s)' on page 23).

The valve must be insulated with closed cell polymer insulation or similar (minimum thickness 9 mm) and the insulation installed so as not to impede the operation of the valve. The insulation must be weatherproof and UV resistant if exposed.

### Solar Storage Cylinder Hot Water Outlet

The premises hot water pipe work connects directly to the solar storage cylinders hot water outlet. To reduce heat loss, the hot water line from the solar storage cylinder must be insulated in accordance with the requirements of AS/NZS 3500.4. The insulation must be weatherproof and UV resistant if exposed.

### Solar Storage Cylinder Solar Hot Water Inlet & Solar Cold Water Outlet

The solar storage cylinder solar hot water inlet is marked 'Connection for Solar Return Pipe'. The bleed valve and solar hot pipe connect to this fitting (hot water return from collectors).

The solar storage cylinder solar cold water outlet is marked 'Connection for Solar Pump'. This circulator and solar cold pipe connect to this fitting (cold water flow to collectors).

Refer to 'Solar Controller Kit Plumbing & Plumbing Connections' on page 23 for details on these plumbing connections.



## Relief Valve Drain(s)

DN15 copper drain lines must be fitted to the pressure temperature relief valve and expansion control valve (if one is installed) to carry the discharge clear of the solar water heater. Connect the drain lines to the valves using disconnection unions. The drain line from the valve to the point of discharge should be as short as possible, have a continuous fall all the way from the solar water heater to the discharge outlet and have no tap, valves or other restrictions in the pipe work. A drain line from a relief valve must comply with the requirements of AS/NZS 3500.4.

A drain line must be no longer than 9 metres with no more than three bends greater than 45° before discharging at an outlet or air break. The maximum length of 9 metres for a drain line is reduced by 1 metre for each additional bend required of greater than 45°, up to a maximum of three additional bends. Where the distance to the point of final discharge exceeds this length, the drain line can discharge into a tundish.

Subject to local regulatory authority approval, the drain lines from the pressure temperature relief valve and expansion control valve from an individual solar water heater may be interconnected.

The outlet of a drain line must be in such a position that flow out of the pipe can be easily seen, but arranged so discharge will not cause injury, damage or nuisance. The termination point of a drain line must comply with the requirements of AS/NZS 3500.4. Drain lines must not discharge into a safe tray.

In locations where water pipes are prone to freezing, drain lines must be insulated, must not exceed 300mm in length and are to discharge into a tundish through an air gap of between 75mm and 150mm.

If a drain line discharges into a tundish, the drain line from the tundish must be not less than DN20. The drain line from a tundish must meet the same requirements as for a drain line from a relief valve.

**⚠ Warning:** *As the function of the pressure temperature relief valve on this solar water heater is to discharge high temperature water under certain conditions, it is strongly recommended the pipe work downstream of the relief valve be capable of carrying water exceeding 99°C. Failure to observe this precaution may result in damage to pipe work and property.*

**Note:** A drain line is also required for the solar circuit bleed valve (refer to 'Bleed Valve Drain' on page 23).

## Pipe sizes

To achieve true mains pressure operation, the cold water line to the solar storage cylinder should be the same size or larger than the hot water line from the solar storage cylinder.

System pipe work must be sized according to the individual application by persons competent to do so. Reference to the technical specifications of the solar water heater and local regulatory authority requirements must be made.

## Pipe Work Insulation

To reduce heat loss, the cold water line to the solar storage cylinder and the hot water line from the solar storage cylinder hot water outlet must be insulated in accordance with the requirements of AS/NZS 3500.4. The insulation must be weatherproof and UV resistant if exposed.

The full length of the solar hot and solar cold pipes between the solar storage cylinder and the solar collectors **MUST BE** insulated. Refer to 'Warning: Important Notes for Plumber' on page 26.

## Saddling Pipe Work

To prevent damage to the solar storage cylinder when attaching pipe clips or saddles to the solar storage cylinder jacket, we recommend the use of self drilling screws with a maximum length of 13mm. Should pre drilling be required, extreme caution must be observed when penetrating the jacket of the solar storage cylinder. If the solar storage cylinder is damaged as a result of attaching pipe clips or saddles to the jacket, any resultant faults will not be covered by the Aquamax warranty.

## Solar Controller Kit Plumbing & Plumbing Connections

---

Refer to the installation instructions supplied with the solar controller kit for details on the installation and plumbing of the solar controller kit.

Refer to 'Solar Controller Kit Installation' on page 18 for an overview of the solar controller kit.

## Bleed Valve Drain

A DN15 copper drain line must be fitted to the bleed valve to carry any discharge clear of the solar water heater and solar control unit. Connect the drain line to the bleed valve using a disconnection union. The pipe



work from the bleed valve to the drain should be as short as possible and must have continuous fall from the valve to the drain with no restrictions. The drain line must have no more than three right angle bends.

The outlet of a drain line must be in such a position that flow out of the pipe can be easily seen, but arranged so that discharge will not cause injury, damage, nuisance or splashing. The termination point of a drain line must comply with the requirements of AS/NZS 3500.4.

The drain line must be fully insulated with closed cell type insulation or similar (minimum thickness 13 mm), capable of withstanding the temperature of the water generated by the solar collectors under stagnation conditions which may be up to 150 °C. The insulation must be weatherproof and UV resistant if exposed.

**⚠ Warning:** Under certain circumstances the water discharged from the bleed valve drain line may be of a very high temperature.

## Solar Collector Circuit Plumbing & Plumbing Connections

All pipe work must be purged and cleared of foreign matter before connection and before attempting to operate the solar water heater.

The solar circulating pump plumbing connection is located at the bottom right hand side of the solar storage cylinder and is marked 'Connection for Solar Pump'. This outlet connects to the solar control unit circulating pump which when energised pumps cold water from the bottom of the solar storage cylinder to the solar collectors via the solar cold pipe.

The solar hot water return plumbing connection is located at the mid left hand side of the solar storage cylinder and is marked 'Connection for Solar Return Pipe'. The bleed valve solar hot pipe are connected to this inlet which allows hot water from the collectors to enter the solar storage cylinder.

It is important not to cross connect solar cold and solar hot pipes to incorrect connections.

- The solar cold pipe (pipe work from the circulating pump) connects to the bottom of the solar collector and may connect to either the left or right hand side of the solar collector.
- The solar hot pipe (return pipe work) must connect to the top of the solar collector diagonally opposite to the solar cold pipe connection.

The hot sensor connection is at the solar hot outlet where the solar hot pipe connects to the solar collector

## Solar Pipe Lengths

The solar hot and solar cold pipes between the solar storage cylinder and the solar collectors shall;

- be of bendable grade or hard drawn copper tube. Annealed or soft copper must not be used.
- have a continuous fall from the solar collectors to the solar storage cylinder. Horizontal runs of pipe work are acceptable and may be installed.
- not exceed the maximum recommended combined lengths as specified in the following table:

Maximum recommended total combined pipe length (solar cold + solar hot) and number of 90° bends				
Pipe Size	2 Collectors		3 Collectors	
	Pipe Length	90° Bends	Pipe Length	90° Bends
DN15	40 metres	20	30 metres	20
DN20	NR	NR	40 metres	20

For each additional 90° bend, reduce the maximum total pipe length by 0.5 metres.

For each additional metre of pipe length, reduce the number of 90° bends by two.

**Note:** One 90° elbow is equal to two 90° bends.

NR – not recommended.

It is essential for these requirements to be followed for the solar water heater to operate correctly and efficiently. Solar pipe work which is oversized, or is too long, or does not have a continuous fall can result in a reduction in performance or the solar water heater not operating effectively.

## Maximum Height to Collectors

The maximum height of a solar installation from the solar control unit (circulator) to the top of the solar collectors, is determined by the maximum recommended total pipe length for the system and the water supply pressure.

The maximum recommended total pipe length of the solar circuit should not be exceeded and a minimum water supply pressure of 200 kPa should be available at the inlet to the solar water heater, otherwise system performance may be reduced or the solar circuit may not be purged of air during commissioning of the solar water heater.

Refer to the installation instructions supplied with the collector kit for details on the installation of the solar collectors.

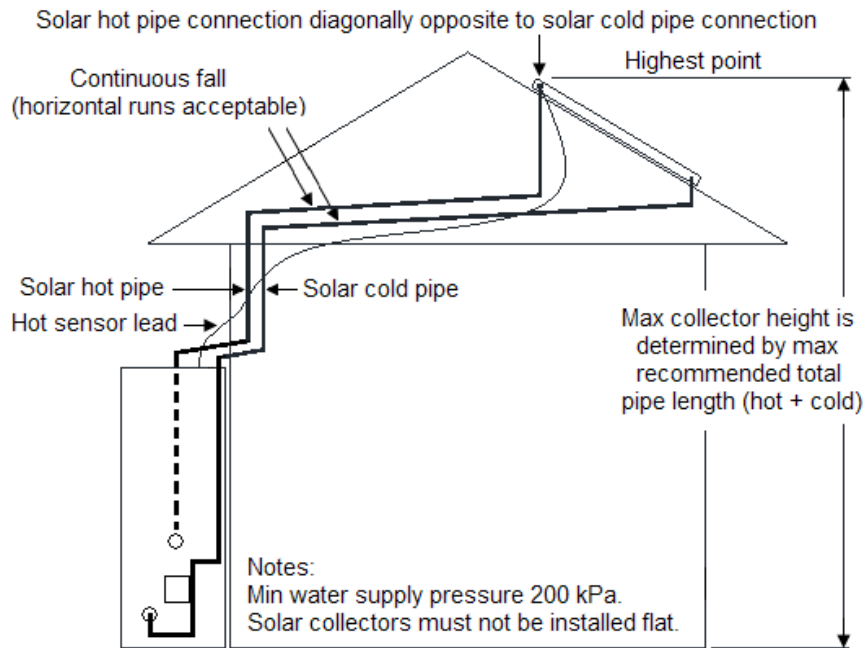

### Solar Pipe Work & Insulation

Refer to 'Warning: Important Notes for Plumber' on page 26.



## **WARNING: Important Notes for Plumber**

- The solar hot and solar cold pipe work between the storage cylinder and the solar collectors and the pipe work between this solar water heater and a temperature limiting device, or this solar water heater and a hot water outlet if a temperature limiting device is not installed **MUST BE** of copper. All compression fittings must use brass or copper olives.
- The full length of the solar hot and solar cold pipes **MUST BE** insulated.

The insulation must;

- be of a closed cell type or equivalent, suitable for a solar water heating application and capable of withstanding the temperature of the water generated by the solar collectors under stagnation conditions which may be up to 150°C. The specification of the chosen insulation material should be checked with the insulation manufacturer prior to installation as different materials may vary in temperature tolerance.
- be at least 13 mm thick, however thicker insulation may be required to comply with the requirements of AS/NZS 3500.4.
- be weatherproof and UV resistant if exposed.
- extend through any penetrations in the eaves, ceiling and roof.
- cover valves and fittings in the solar hot and solar cold pipe work.
- be fitted up to and cover the connections on both the solar storage cylinder and the solar collectors.

**Note: Failure to observe these requirements increases the risk of freeze damage.**

Uninsulated pipe work, including uninsulated pipe work concealed in cavities and roof spaces or where it may be in contact with a metal roof, may lead to freeze damage. The system has NO WARRANTY for freeze damage if the solar hot and solar cold pipes are not insulated in accordance with the installation instructions.

Pipe work insulation is essential to assist in;

- providing freeze protection.
- providing corrosion protection to a metal roof from water runoff over the copper pipe.
- avoiding accidental contact with the solar pipe work which can become very hot as high temperature water can flow from the solar collectors to the solar storage cylinder.
- reducing pipe heat losses.

The insulated copper pipe work;

- should be fixed at suitable locations to prevent or reduce the possibility of noise from water hammer and vibration from occurring.
- is not to be placed or installed in contact with plastic pipe work.

Likewise, plastic pipe work is not to be placed or installed in contact with the insulated copper pipe work after the solar circuit is installed.

- Plastic pipe **MUST NOT** be used, as it will not withstand the temperature and pressure of the water generated by the solar collectors under stagnation conditions. The solar collectors can generate extremely high water temperatures up to 150°C and high water pressure of 1000 kPa. Plastic pipe cannot withstand these temperatures and pressures and **MUST NOT** be used. Failure of plastic pipe can lead to the release of high temperature water and cause severe water damage and flooding.
- The highest point of the solar cold pipe and solar hot pipe must be where they connect to the solar collectors, to avoid the possibility of air locks occurring in the system. There **must be a continuous fall** in the pipe work between the solar collectors and solar storage cylinder. Horizontal runs of pipe work are acceptable and may be installed.
- A non return valve **MUST BE** installed on the cold water line to the solar storage cylinder **AFTER** the cold water branch to a temperature limiting device. Due to the high water temperatures generated under certain conditions in the solar collectors of this solar water heater, an additional effective back-flow prevention device also should be used as an extra safeguard. Valve manufacturer RMC recommends Dual Check Valve model N7150, as being suitable for this application.
- The pressure applied to the solar circuit and solar collectors during a pressure test **MUST NOT** exceed 1000 kPa, otherwise damage may result to the solar collectors.

### Two Temperature Zones Using a Temperature Limiting Device

This solar water heater can deliver water at temperatures which can cause scalding.

It is necessary and we recommend that a temperature limiting device be fitted between the solar water heater and the hot water outlets in any ablution area such as a bathroom or ensuite, to reduce the risk of scalding.

The installing plumber may have a legal obligation to ensure the installation of this solar water heater meets the delivery water temperature requirements of AS/NZS 3500.4 so that scalding water temperatures are not delivered to a bathroom, ensuite or other ablution area.

The temperature limiting device used with a solar water heater should be capable of receiving a hot water supply temperature of up to 99°C and have a specified 'minimum temperature differential' between the hot water inlet and the tempered water outlet of no greater than 10°C. Refer to the specifications of the temperature limiting device.

Where a temperature limiting device is installed adjacent to the solar water heater, the cold water line to the temperature limiting device can be branched off the cold water line either before or after the isolation valve and pressure limiting valve to the solar storage cylinder, but it **MUST BE** before the non return valve. If an expansion control valve is required, it must always be installed after the non return valve and be the last valve prior to the solar storage cylinder.

**⚠ Warning:** A non return valve **MUST BE** installed on the cold water line to the solar storage cylinder **AFTER** the cold water branch to a temperature limiting device. Due to the high water temperatures generated under certain conditions in the solar collectors of this solar water heater, an additional effective back-flow prevention device also should be used as an extra safeguard. Valve manufacturer RMC recommends Dual Check Valve model N7150, as being suitable for this application.

If a pressure limiting valve is installed on the cold water line to the solar water heater and the cold water line to a temperature limiting device branches off before this valve or from another cold water line in the premise, then a pressure limiting valve of an equal pressure setting may be required prior to the temperature limiting device.

If a combination isolation valve and non return valve (duo or trio valve) is installed on the cold water line to the solar water heater and the cold water line to the temperature limiting device branches off after this valve, then a second non return valve must be installed between the cold water branch and the solar water heater. Due to the high water temperatures generated under certain conditions in the solar collectors of this solar water heater, an effective back-flow prevention device should be used as the second non return valve as an extra safeguard. Valve manufacturer RMC recommends Dual Check Valve model N7150, as being suitable for this application.

Refer to 'Two Temperature Zone Plumbing Diagram – Electric Boosted Solar System' on page 28.

### Circulated Hot Water Flow & Return Systems

The solar storage cylinder of a solar water heater should not be installed as part of a circulated hot water flow and return system in a building. The benefits of solar gain will be significantly reduced and energy gained from the sun lost through the pipe work.

If a circulated flow and return system is required, it is necessary to install a secondary (booster) storage water heater which is connected to the hot water flow and return line and supplied from the solar storage cylinder. Aquamax EM50 model water heaters are suitable for use as the secondary water heater provided it has been determined that hot water demand can be met (the secondary water heater has been suitably sized) and the EM50 thermostat has been set to 70°C to meet the requirements of AS 3498. **Note:** The EM50 thermostat factory setting is 70°C.

For circulated hot water flow and return systems, a temperature limiting device can only be installed on a dead leg which branches off the circulated hot water flow and return pipe.

**⚠ Warning:** Installing a temperature limiting device in the circulated flow and return pipe work, or circulating tempered water from a temperature limiting device may cause water to be delivered to ablution areas at a temperature exceeding the requirements of AS/NZS 3500.4.

Refer to 'Circulated Flow & Return Plumbing Diagram – Electric Boosted Solar System' on page 28.



## INSTALLATION – ELECTRICAL & ELECTRICAL CONNECTIONS

---

**⚠ Warning:** The power supplies to the solar water heater and solar control unit must not be switched on until the solar water heater is filled with water and a satisfactory megger reading is obtained.

All electrical work and permanent wiring must be carried out by a qualified person and in accordance with the Wiring Rules AS/NZS 3000 and all local codes and regulatory authority requirements.

### Solar Control Unit Electrical & Electrical Connections

---

The solar control unit is designed to be mounted on the side of the solar storage cylinder above the solar cold water outlet. The solar control unit is supplied with a 1.8 metre power cord and requires a 240 V 50 Hz general purpose outlet (GPO) to be located within 1.2 metres of the installation. The GPO must have a continuous power supply originating from a circuit other than the water heater circuit and is required to be weatherproof if installed outdoors. For full installation details, refer to the Installation Instructions supplied with the solar controller kit.

If the power supply cord or plug is damaged, it must be replaced by an authorised person in order to avoid a hazard. The power supply cord and plug must be replaced with a genuine replacement part available from the manufacturer.

**Note:** This solar water heater will only operate on a sine wave at 50 Hz. Devices generating a square wave cannot be used to supply power to the solar control unit. The power consumption of the solar control unit is 4 Watts and the maximum power consumption of the solar circulator is 36 Watts.

### Electric Booster Electrical & Electrical Connections

---

The solar storage cylinder's electric booster circuit must be directly connected to a dedicated 240V AC, 50Hz continuous tariff mains power supply with over current protection and an isolating switch installed at the switchboard. The power supply wires insulation temperature rating and current carrying capacity must be suitable for this application.

Connect the power supply wires directly to the solar water heaters terminal block and earth tab connection as shown in the wiring diagram provided on the rear of the solar storage cylinders electrical access cover. Ensure there are no excess wire loops inside the front cover.

A 20mm flexible conduit is required to protect the wiring to the water heater. The conduit is to be connected to the solar water heater with an approved 20mm flexible conduit terminator.

**Note:** Remove yellow warning label from conduit entry before connecting conduit and wiring.

The power consumption of the electric booster is 3.6 kW (4.8 kW also available for SE415 model) when the element is operating.

### Wiring Diagram

Refer to wiring diagram located behind solar storage cylinder access cover.

### Booster Thermostat Adjustment

---

**⚠ Warning:** The booster thermostat and its protective over temperature cut out are mounted behind the front access cover of the solar storage cylinder. The removal of the front access cover will expose 240V wiring. Access covers must only be removed by an electrician or qualified person.

**⚠ Warning:** Booster thermostat temperature adjustment must only be performed by an electrician or qualified person.

The booster thermostat has been factory preset to 60°C. The booster thermostat setting can be set by a qualified person to a minimum of 60°C and a maximum of 70°C; however Aquamax recommends that the booster thermostat is set at 60°C to maximise solar contribution.

To adjust the booster thermostat:

**⚠ Warning:** The thermostat must only be adjusted when power to the solar water heater is isolated.

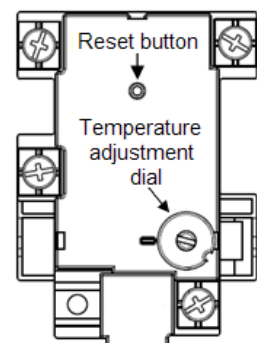



1. Switch off the circuit breaker or isolator marked 'Hot Water' or 'Water Heater' at the switchboard. This will turn off the electric booster circuit.
2. Remove electrical access cover.
3. Turn thermostat temperature adjustment dial clockwise to increase temperature setting or anticlockwise to decrease temperature setting.
4. Replace lower access cover.
5. Switch on the circuit breaker or isolator marked 'Hot Water' or 'Water Heater' at the switchboard. This will turn on the electric booster circuit.

**⚠ Warning:** *The power supplies to the solar water heater must not be switched on until the solar water heater is filled with water and a satisfactory megger reading is obtained.*

### Over Temperature & Energy Cut Out

The operation of the over temperature and energy cut out on the thermostat indicates a possibly dangerous situation. If the over temperature and energy cut out operates, it must not be reset and the solar water heater must be serviced by a qualified person.

## COMMISSIONING

---

### Pressure Testing

It may be necessary to pressure test the collector circuit to comply with codes and regulatory authority requirements, or on other occasions where the solar collectors and solar cold and solar hot pipe work are installed prior to the solar storage cylinder, such as on a building site.

If the solar collectors, solar pipe work and solar storage cylinder are installed and commissioned together, then the flooding of the collector circuit with water under mains pressure and checking the pipe work for leaks during the commissioning procedure can be substituted for the pressure testing of the collector circuit.

If pressure testing is required, the solar water heater, including the collector circuit and solar collectors, is to be isolated during the testing and commissioning of the heated water reticulation system in accordance with Clause 11.1 and 11.3 (a) of AS/NZS 3500.4.

**⚠ Warning:** *The pressure applied to the solar circuit and solar collectors during a pressure test **MUST NOT** exceed 1000 kPa where Aquamax S solar collectors are installed, otherwise damage may result to the solar collectors.*

### Pre Commissioning Procedure

After installation and before commissioning the solar water heater, the following pre commissioning procedure must be performed:

1. Check to ensure that all wiring links and electrical connections are secure and tight.
2. To ensure the over temperature and energy cut out is set, press and release the black reset button on the booster thermostat (refer to diagram in 'Booster Thermostat Adjustment' on page 29).
3. Perform a megger (insulation) test on the solar water heater. If a satisfactory megger reading is obtained the solar water heater can be filled, turned on and commissioned.

### To Fill, Turn ON and Commission the Solar Water Heater

**⚠ Warning:** *The power supplies to the solar water heater must not be switched on until the solar water heater is filled with water and a satisfactory megger reading is obtained.*

1. Open all hot water taps in premises including shower(s).
2. Fully open cold water isolation valve on cold water line to solar storage cylinder. This will purge air from hot water plumbing lines via taps opened in step 1.
3. Close each hot water tap after all air is purged (when air is purged water will run freely without air bubbles or spluttering).
4. Check all plumbing connections for leaks.
5. Purge the collector circuit of air (refer to 'Purging the Solar Collectors' on page 10). **Note:** Air trapped in the system can prevent solar gain from occurring and cause the solar water heater to operate on the electric booster only.

6. Plug in the solar control unit at the power outlet and switch on the electrical supply. **Note:** The power outlet must be switched on for the solar control unit to operate and for solar gain to be achieved. The solar control unit also provides additional freeze protection when energised.

When the electrical supply is switched on to the solar control unit at start up:

- If there is no solar gain, the circulator will not activate and the green LED will emit a slow pulse.

The slow pulse indicates the circulator is not activated and the power to the solar control unit has been on for less than 48 hours.

- If there is solar gain, the circulator activates and the green LED will emit a series of three (3) flashes.

The three (3) flashes indicate the circulator is operating and power to the solar control unit has been on for less than 48 hours.

- The circulator will operate at full speed for approximately fifteen (15) seconds. If the solar monitor red LED is emitting a rapid pulse, the circulator may operate at full speed for up to ten (10) minutes.

After fifteen (15) seconds or after the red LED has extinguished, the solar control unit will commence to pulse the circulator to control the flow rate through the collector circuit. It is normal operation for the circulator to experience a pulsing effect.

- The red LED may emit a rapid pulse for a short period.

This indicates a temperature difference between the hot sensor and cold sensor of greater than 40°C and does not represent a fault code. This is the result of a build-up of heat and an increase in water temperature in the collector(s) prior to switching on the electrical supply to the solar control unit.

The rapid pulsing of the red LED will cease as the water circulates and the heat is dissipated. This should occur within four (4) to five (5) minutes of start up, but may take up to ten (10) minutes.

If the red LED does continue to emit a rapid pulse for longer than ten (10) minutes, this may indicate water is not circulating through the collector(s) and solar circuit;

- Switch off the electrical supply at the power outlet to the solar control unit.
- Repeat the procedure to bleed the solar collectors (refer to 'Purging the Solar Collectors' on page 10).
- Switch on the electrical supply at the power outlet to the solar control unit.

For more information on the solar monitor, including a list of all operational and fault mode LED indication, refer to 'Solar Monitor LED Indication' on page 14 and the installation instructions supplied with the Solar Controller Kit.

7. Switch on the circuit breaker or isolator marked 'Hot Water' or 'Water Heater' at the switchboard. This will turn on the electric booster circuit.
8. Explain to the householder, or a responsible officer, the functions and operation of the solar water heater. Leave this guide and all other guides supplied with each component of the solar water heater with the householder or responsible officer upon completion of the installation and after commissioning.

### To Turn OFF the Solar Water Heater

Sometimes it is necessary to turn off the solar water heater after installation and commissioning. This may be required on a building site or where the premises are vacant. If it is necessary to turn off the solar water heater:

1. Switch off the circuit breaker or isolator marked 'Hot Water' or 'Water Heater' at the switchboard. This will turn off the electric booster circuit.
2. Switch off the electrical supply at the power outlet to the solar control unit. **Note:** The Aquamax warranty does not cover damage caused by freeze conditions when the electrical circuit or electrical supply to the solar control unit is turned off or interrupted. If there is a risk of freezing conditions, then it is necessary to drain the solar collectors and solar flow and return pipe work (refer to 'Draining the Solar Collectors' on page 32).
3. Close the cold water isolation valve at the inlet to the solar storage cylinder.

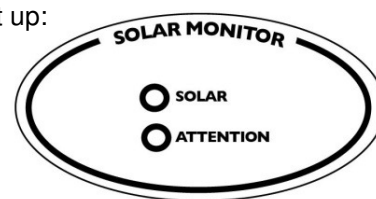



## Draining the Solar Collectors

---

### To drain the solar collectors and the solar hot and solar cold pipes:

**⚠ Warning:** Exercise care when performing the following procedure as water discharged from the solar collectors and solar circuit may be of a very high temperature. Wear personal protective equipment to reduce the risk of scalding.

1. Switch off the circuit breaker or isolator marked 'Hot Water' or 'Water Heater' at the switchboard. This will turn off the electric booster circuit.
2. Open a hot water tap and allow the water to run for five minutes immediately prior to draining the solar collectors. This will assist in the transfer of any high temperature water in the solar collectors to the solar storage cylinder.
3. Close the hot water tap.
4. Switch off the electrical supply at the power outlet to the solar control unit.
5. Close the cold water isolation valve at the inlet to the solar storage cylinder.
6. Using a flat bladed screwdriver, rotate the bleed valve screw to the open position. The bleed valve is located on the solar hot water inlet (from collector) of the solar storage cylinder (labelled 'Connection for Solar Return Pipe'). Refer to diagram in the 'Purging the Solar Collectors' section on page 10.
7. Undo the compression fitting at the connection of the solar cold pipe to the solar storage cylinder and disconnect the solar cold pipe. Water will now drain from the solar collectors and the solar hot and solar cold pipes (solar hot pipe via bleed valve previously opened in step 6).
8. When water stops flowing from the solar hot and solar cold pipes, reconnect the solar cold pipe to the solar storage cylinder and tighten the compression fitting.
9. Using a flat bladed screwdriver, close the bleed valve.

### To refill the solar collectors after draining and reinstate the solar water heater:

1. Open all hot water taps in premises including shower(s).
2. Fully open cold water isolation valve on cold water line to solar storage cylinder. This will purge air from hot water plumbing lines via taps opened in step 1.
3. Close each hot water tap after all air is purged (when air is purged, water will run freely without air bubbles or spluttering).
4. Check compression fitting at the connection of the solar cold pipe to the solar storage cylinder for leaks.
5. Purge the collector circuit of air (refer to 'Purging the Solar Collectors' on page 10). **Note:** Air trapped in the system can prevent solar gain from occurring and cause the system to operate on the electric booster only.
6. Switch on the electrical supply at the power outlet to the solar control unit. **Note:** The power outlet must be switched on for the solar control unit to operate and for solar gain to be achieved. The solar control unit also provides additional freeze protection when energised.
7. Switch on the circuit breaker or isolator marked 'Hot Water' or 'Water Heater' at the switchboard. This will turn on the electric booster circuit.

## Draining the Solar Storage Cylinder

---

**⚠ Warning:** Water discharged from the solar water heater during this procedure may be of a very high temperature. Wear personal protective equipment to reduce the risk of scalding.

To drain the solar storage cylinder:

1. Switch off the circuit breaker or isolator marked 'Hot Water' or 'Water Heater' at the switchboard. This will turn off the electric booster circuit.
2. Open a hot water tap and allow the water to run for five minutes immediately prior to draining the solar storage cylinder. This will assist in the transfer of any high temperature water in the solar collectors to the solar storage cylinder.
3. Close the hot water tap.
4. Switch off the electrical supply at the power outlet to the solar control unit.

5. Close the cold water isolation valve at the inlet to the solar storage cylinder.
6. Close all hot water taps in premises.
7. Operate PTR valve lever for a period of five seconds to release pressure in solar storage tank. **Note:** Operate lever gently and do not let lever snap back or you will damage relief valve seat.
8. Undo union at cold water inlet to solar storage cylinder and attach a hose to solar storage cylinder side of union. Run other end of hose to a drain.
9. Operate PTR valve lever until all water has drained from solar storage cylinder. Operating PTR valve lever will let air into the solar storage cylinder which will allow water to drain through hose.

**To refill the solar storage cylinder after draining and reinstate the solar water heater:**

1. Reconnect union at cold water inlet to solar storage cylinder and tighten.
2. Open all hot water taps in premises including shower(s).
3. Fully open cold water isolation valve on cold water line to solar storage cylinder. This will purge air from hot water plumbing lines via taps opened in step 2.
4. Close each hot water tap after all air is purged (when air is purged water will run freely without air bubbles or spluttering).
5. Check union at solar storage cylinder cold water inlet for leaks.
6. Purge the collector circuit of air (refer to 'Purging the Solar Collectors' on page 10). **Note:** Air trapped in the system can prevent solar gain from occurring and cause the solar water heater to operate on the electric booster only.
7. Switch on the electrical supply at the power outlet to the solar control unit. **Note:** The power outlet must be switched on for the solar control unit to operate and for solar gain to be achieved. The solar control unit also provides additional freeze protection when energised.
8. Switch on the circuit breaker or isolator marked 'Hot Water' or 'Water Heater' at the switchboard. This will turn on the electric booster circuit.

## Dimensions and Technical Data

### Solar Electric Boosted Solar Water Heater SE415 ~ SE260 Models

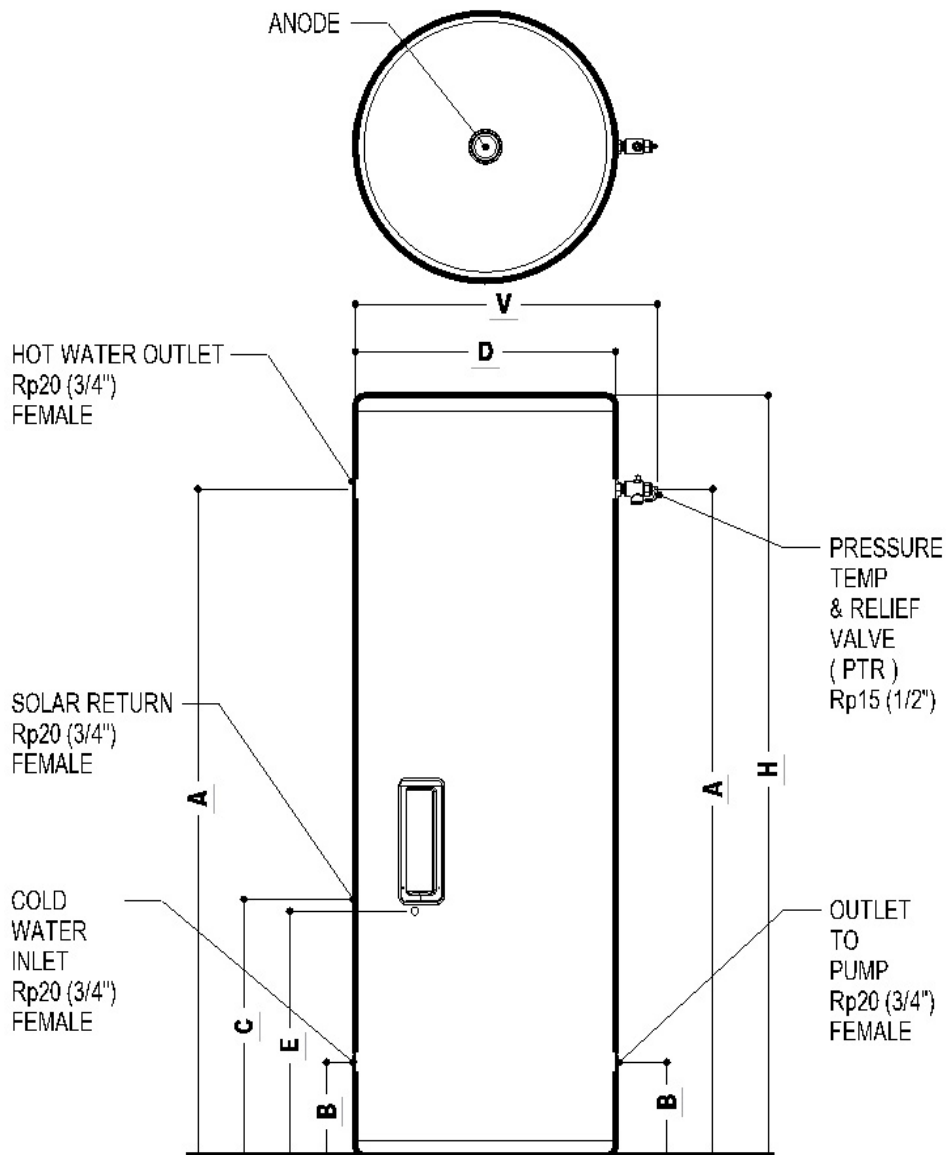

Model		SE415	SE325	SE260
<b>Capacity (L)</b>		415	325	260
<b>Weight (kg)</b>	<b>Empty</b>	100	90	75
	<b>Full</b>	515	415	335
<b>Dimensions</b>				
<b>A (mm)</b>		1525	1535	1215
<b>B (mm)</b>		230	215	215
<b>C (mm)</b>		565	590	530
<b>D (mm)</b>		685	620	620
<b>H (mm)</b>		1760	1755	1435
<b>V (mm)</b>		780	715	715
<b>Max Supply Pressure</b>				
<b>With ECV (kPa)</b>		680	680	680
<b>Without ECV (kPa)</b>		800	800	800
<b>ECV Setting (kPa)</b>		850	850	850
<b>PTR Valve (kPa)</b>		1000	1000	1000

Technical data is subject to change.

This page is intentionally blank

This page is intentionally blank

This page is intentionally blank

# WARRANTY

---

## AQUAMAX SOLAR WATER HEATER SE415, SE325 & SE260

### 1. THE AQUAMAX WARRANTY – GENERAL

- 1.1 This warranty is given by Aquamax Australia Pty Limited ABN 37 138 189 689 of 463-467 Warrigal Road, Moorabbin Victoria.
- 1.2 Aquamax offer a trained and qualified service network who will repair or replace components at the address of the water heater subject to the terms of the Aquamax warranty. Aquamax Service, in addition can provide preventative maintenance and advice on the operation of your water heater. The Aquamax Service contact number is available 7 days a week on 1800 676 000 from 9am to 5pm, excluding public holidays (hours subject to change without notification)
- 1.3 For details about this warranty, you can contact us on 1800 676 000 or by email at [service@aquamax.com.au](mailto:service@aquamax.com.au) (not for service bookings).
- 1.4 The terms of this warranty are set out in section 2 and apply to water heaters manufactured after 1st October 2012.
- 1.5 If a subsequent version of this warranty is published, the terms of that warranty will apply to water heaters manufactured after the date specified in the subsequent version.

### 2. TERMS OF THE AQUAMAX WARRANTY AND EXCLUSIONS TO IT

- 2.1 The decision of whether to repair or replace a faulty component is at Aquamax's sole discretion.
- 2.2 If you require a call out and we find that the fault is not covered by the Aquamax warranty, you are responsible for our standard call out charge. If you wish to have the relevant component repaired or replaced by Aquamax, that service will be at your cost.
- 2.3 Where a failed component or cylinder is replaced under this warranty, the balance of the original warranty period will remain effective. The replacement does not carry a new Aquamax warranty.
- 2.4 Where the water heater is installed outside the boundaries of a metropolitan area as defined by Aquamax or further than 25 km from either a regional Aquamax branch office or an Accredited Aquamax Service Agent's office, the cost of transport, insurance and travelling between the nearest branch office or Aquamax Accredited Service Agent's office and the installed site shall be the owner's responsibility.
- 2.5 Where the water heater is installed in a position that does not allow safe or ready access, the cost of that access, including the cost of additional materials handling and/or safety equipment, shall be the owner's responsibility. In other words, the cost of dismantling or removing cupboards, doors or walls and the cost of any special equipment to bring the water heater to floor or ground level or to a serviceable position is not covered by this warranty.
- 2.6 This warranty only applies to the original and genuine Aquamax water heater in its original installed location and any genuine Aquamax replacement parts.
- 2.7 The Aquamax warranty does not cover faults that are a result of:
  - a) Accidental damage to the water heater or any component (for example: (i) Acts of God such as floods, storms, fires, lightning strikes and the like; and (ii) third party acts or omissions).
  - b) Misuse or abnormal use of the water heater.
  - c) Installation not in accordance with the Owner's Guide and Installation Instructions or with relevant statutory and local requirements in the State or Territory in which the water heater is installed.
  - d) Connection at any time to a water supply that does not comply with the water supply guidelines as outlined in the Owner's Guide and Installation Instructions.
  - e) Repairs, attempts to repair or modifications to the water heater by a person other than Aquamax Service or an Aquamax Accredited Service Agent.
  - f) Faulty plumbing or faulty power supply.
  - g) Failure to maintain the water heater in accordance with the Owner's Guide and Installation Instructions.
  - h) Transport damage.
  - i) Fair wear and tear from adverse conditions (for example, corrosion).
  - j) Cosmetic defects.
  - k) Ice formation in the waterways of a water heater system incorporating a freeze protection system where the electricity supply has been switched off or has failed or where it is installed at an altitude more than 400 metres above sea level.
  - l) Breakage of collector glass for any reason including hail damage (we suggest that the collector glass be covered by your home insurance policy).

- 2.8 Subject to any statutory provisions to the contrary, this warranty excludes any and all claims for damage to furniture, carpet, walls, foundations or any other consequential loss either directly or indirectly due to leakage from the water heater, or due to leakage from fittings and/ or pipe work of metal, plastic or other materials caused by water temperature, workmanship or other modes of failure.
- 2.9 If the water heater is not sized to supply the hot water demand in accordance with the guidelines in the Aquamax water heater literature, any resultant fault will not be covered by the Aquamax warranty.

### 3. WHAT IS COVERED BY THE AQUAMAX WARRANTY FOR THE WATER HEATERS DETAILED IN THIS DOCUMENT

- 3.1 Aquamax will repair or replace a faulty component of your water heater if it fails to operate in accordance with its specifications as follows:

What components are covered	The period in which the fault must appear in order to be covered	What coverage you receive
All components	Year 1	Repair and/or replacement of the faulty component, free of charge, including labour.
<b>The cylinder</b> (if the water heater is installed in a single-family domestic dwelling)	Years 2 to 5	Repair and/or Replacement cylinder, free of charge. Installation and repair labour costs are the responsibility of the owner.
<b>The cylinder</b> (if the water heater is <u>not</u> installed in a single-family domestic dwelling)	Years 1	Repair and/or replacement of the faulty component, free of charge, including labour.
<b>The solar collector</b> (all installations)	Years 2 to 5	Replacement solar collector, free of charge. Installation and repair labour costs are the responsibility of the owner.

- 3.2 If a government rebate has been received for the water heater, the duration of the protection afforded by this warranty may be greater than what is set out above. Please call 1800 676 000 for details.

#### 4. Entitlement To Make A Claim Under This Warranty

- 4.1 To be entitled to make a claim under this warranty you need to:
- Be the owner of the water heater or have consent of the owner to act on their behalf.
  - Contact Aquamax Service without undue delay after detection of the defect and, in any event, within the applicable warranty period.
- 4.2 You are not entitled to make a claim under this warranty if your water heater:
- Does not have its original serial numbers or rating labels.
  - Is not installed in Australia.

#### 5. How To Make A Claim Under This Warranty

- 5.1 If you wish to make a claim under this warranty, you need to:
- Contact Aquamax on 1800 676 000 and provide owner's details, address of the water heater, a contact number and date of installation of the water heater or if that's unavailable, the date of manufacture and serial number (from the rating label on the water heater).
  - Aquamax will arrange for the water heater to be tested and assessed on-site.
  - If Aquamax determines that you have a valid warranty claim, Aquamax will repair or replace the water heater in accordance with this warranty.
- 5.2 Any expenses incurred in the making of a claim under this warranty will be borne by you.

#### 6. The Australian Consumer Law

- 6.1 Our goods come with guarantees that cannot be excluded under the Australian Consumer Law. You are entitled to a replacement or refund for a major failure and for compensation for any other reasonably foreseeable loss or damage. You are also entitled to have the goods repaired or replaced if the goods fail to be of acceptable quality and the failure does not amount to a major failure.
- 6.2 The Aquamax warranty (set out above) is in addition to any rights and remedies that you may have under the Australian Consumer Law.



## INSTALLER INFORMATION

DEAR INSTALLER,

Please provide the following information upon completion of the installation. This information should be provided to assist the customer in the event that a claim is made under the Aquamax warranty.

**Plumber (Name & Company):**

**Plumber's licence number:**

**Compliance Certificate:**  
*(if applicable in your state)*

**Installation date:**

**Model & serial number:**

**Water Heater date of manufacture:**

<b>AQUAMAX AUSTRALIA PTY.LTD</b> ABN 37 138 189 689 www.aquamax.com.au	FOR SERVICE TELEPHONE <b>1800 676 000</b>
--	--

**NOTE:** Every care has been taken to ensure accuracy in preparation of this publication. No liability can be accepted for any consequences, which may arise as a result of its application.

Revision Date: 10/10/2012

AQ0901038-E