

***Owner's Guide  
and  
Installation Instructions***



**Air Sourced Heat Pump  
Water Heater**

**HP325-36-1B Series**

*This water heater must be installed and serviced by a qualified person.  
Please leave this guide with the householder.*

---

**⚠ Warning:** Upon completion of the installation and commissioning of the water heater, leave this guide with the householder or responsible officer. **DO NOT** leave this guide inside the cover of the water heater or the heat pump module, as it may interfere with the safe operation of the water heater or ignite when the water heater is turned on.

---

#### **Patents**

This water heater may be protected by one or more patents or registered designs in the name of Aquamax Australia Pty Ltd or Rheem Australia Pty Ltd.

#### **Trade Marks**

® Registered trademark of Aquamax Australia Pty Ltd. or Rheem Australia Pty. Ltd.  
™ Trademark of Aquamax Australia Pty Ltd or Rheem Australia Pty Ltd.

**Note:** Every care has been taken to ensure accuracy in preparation of this publication. No liability can be accepted for any consequences, which may arise as a result of its application.

# CONTENTS

---

**Householder:** Read the section “About Your Water Heater” (pages 3 to 15). The “Installation” section is intended for the installer but may be of interest.

ABOUT YOUR WATER HEATER .....	3
Model Type .....	3
Timer Control .....	4
Turning On the Water Heater .....	4
To Turn Off the Water Heater .....	5
Temperature Adjustment .....	5
Other Important Information.....	5
Periodic Maintenance .....	6
Water Chemistry .....	8
Troubleshooting .....	10
Operating Mode Monitor LED Indication.....	14
INSTALLATION .....	16
Installation Overview.....	16
Water Supplies.....	17
INSTALLATION – COMPONENTS .....	18
Water Heater Location .....	18
Heat Pump Module & Storage Cylinder Assembly .....	18
INSTALLATION – PLUMBING & PLUMBING CONNECTIONS .....	20
Heat Pump Plumbing & Plumbing Connections .....	20
General Plumbing Arrangement & Plumbing Diagrams .....	22
Two Temperature Zones Using a Temperature Limiting Device .....	22
Circulated Hot Water Flow & Return Systems .....	23
INSTALLATION – ELECTRICAL & ELECTRICAL CONNECTIONS .....	24
Heat Pump Electrical & Electrical Connections .....	24
Booster Thermostat Adjustment .....	24
Wiring Diagram .....	25
COMMISSIONING .....	26
To Fill & Turn On the Water Heater .....	26
Draining the Water Heater .....	27
Dimensions & Technical Data.....	28
WARRANTY .....	29

# ABOUT YOUR WATER HEATER

---

## Water Heater Application

This water heater is designed for use in a single family domestic dwelling for the purpose of heating potable water. Its use in an application other than this may shorten its life.

**⚠ Warning:** *This water heater is only intended to be operated by persons who have the experience or the knowledge and the capabilities to do so. This water heater is not intended to be operated by persons with reduced physical, sensory or mental capabilities i.e. the infirm, or by children. Children should be supervised to ensure they do not interfere with the water heater.*

## Model Type

---

Your Aquamax<sup>®</sup> air sourced heat pump water heater is designed for outdoor installation only. The model you have chosen is a HP325-36-1B and is recommended for connection to a minimum 16 hour per day power supply.

An Aquamax heat pump water heater consumes less energy than an electric water heater. The impact on an electricity account will depend on the tariff arrangement of the water heater replaced and where you live. Contact your energy provider for more information on tariff arrangements and cost comparisons.

## Model Selection Chart

The model number shown below applies to the heat pump water heater which is made of two main components, the storage cylinder and heat pump module.

<b>325 Litre</b>
HP325-36-1B

**Note:** All models can be supplied with a 'Hard Water Anode'. These models have the suffix 'HWA' at the end of the model number of the storage cylinder component.

## Legend

<b>HP325</b>	Heat Pump storage cylinder capacity in litres 240V AC, 50Hz
<b>36</b>	Element wattage (3600W)
<b>1B</b>	One B series heat pump module

## Heat Pump Operation

Water is stored in a vitreous enamel lined steel cylinder. The water heater's evaporator absorbs heat from the surrounding air and transfers this heat into the water in the storage cylinder.

When hot water is drawn off and cold water enters the storage cylinder, the controller activates a fan, a compressor and a circulating pump. The fan draws outside air in through the air inlet louvres at the side of the heat pump module and the circulating pump circulates water from the bottom of the storage cylinder through the heat exchanger. Heat is absorbed from the surrounding air by an evaporator and transferred into the water flowing through the heat exchanger. The resulting cold air is then discharged through the air outlet grille back to atmosphere and the heated water is circulated back into the storage cylinder. This process continues while heating is required until the water in the storage cylinder reaches a temperature of 60°C.

Even on cloudy or cold days, heat is drawn from the surrounding air. The heat pump will operate when the ambient air temperature is between a minimum of 3°C to 5°C and a maximum of 45°C to 55°C. The electric booster (heating unit or element) will operate when the ambient air temperature is outside of this temperature range if heating is required. The efficiency of the water heater increases as the ambient air temperature increases within the operating range of the heat pump.

Automatic safety controls are fitted to the water heater to provide safe and efficient operation.

## Electric Booster Operation

If the ambient air temperature falls below 7°C and the heat pump has been operating for an extended period, ice may begin to form on the evaporator reducing heat pump efficiency. At ambient air temperatures below 3°C to 5°C, the water heater will deactivate heat pump operation and switch to booster heating mode. When operating in booster heating mode the water in the storage cylinder is heated by the booster heating unit to a temperature of 70°C and the evaporator will defrost if necessary.

At ambient air temperatures above 45°C to 55°C, the water heater will deactivate heat pump operation and switch to booster heating mode to protect the heat pump from overheating. When operating in booster

heating mode, the water in the storage cylinder is heated by the booster heating unit to a temperature of 70°C.

If the heat pump detects certain fault conditions, the water heater will deactivate heat pump operation and switch to backup heating mode to ensure a supply of hot water. When operating in backup heating mode the water in the storage cylinder is heated by the booster heating unit to a temperature of 70°C.

The boost capacity of a HP325-36-1B model heat pump when operating in boost or backup heating mode is 206 litres.

### **Mains Pressure Operation**

The water heater is designed to operate at mains pressure by connecting directly to the mains water supply. If the mains supply pressure in your area exceeds that shown in “Mains Water Supply” on page 17 a pressure limiting valve must be fitted. The supply pressure should be greater than 350 kPa for true mains pressure operation to be achieved. A minimum water supply pressure of 200 kPa is required to enable the heat pump circulator and heat pump system to operate effectively.

### **High Hot Water Temperature Increases the Risk of Scald Injury**

**⚠ Warning:** *This water heater can deliver water at temperatures which can cause scalding. Always check the water temperature before use, such as when entering a shower or filling a bath or basin, to ensure it is suitable for the application and will not cause scald injury. Aquamax recommends monthly temperature checks to ensure the appropriate temperature is maintained within the hot water heater.*

Aquamax recommends, and it may also be required by regulations, that a secondary device such as an approved temperature limiting device or anti-scald water shut off valve be fitted into the hot water pipe work to the bathroom(s) and ensuite(s) if persons living in the house require additional safety protection from potential scalding. This will keep the hot water supply temperature to the bathroom(s) and ensuite(s) below 50°C which will reduce the risk of scald injury whilst still allowing hotter water (60°C+) to the kitchen and laundry.

For new hot water installations, all sanitary outlet fixtures used primarily for personal hygiene purpose must deliver hot water not exceeding 50°C. This temperature limit is not mandatory for kitchen sinks and laundry tubs.

To minimise scalding, especially for those people in high scald risk categories i.e. young children, people with potentially incapacitating medical conditions, elderly people etc, this water heater must be installed in accordance with AS/NZS 3500.4.

For early childhood centres, primary and secondary schools, nursing homes or similar facilities for young, aged, sick or disabled persons, please consult your local health authority for the correct temperature setting.

### **Timer Control**

---

A timer can be installed in the electrical circuit to the water heater. The timer must be weatherproof if it is installed outdoors.

It may be desirable for the water heater not to operate between certain hours, such as during the peak period when connected to a “Time of Use” electricity supply due to a more expensive tariff rate applying.

A timer will affect the operating times of both the heat pump circuit and the booster heating unit.

**Note:** The HP325-36-1B model water heater is recommended for connection to a minimum 16 hour per day power supply.

### **Turning On the Water Heater**

---

To turn on the water heater:

1. Fully open the cold water isolation valve at the cold water inlet to the water heater.
2. Switch on the electrical supply at the isolating switch to the water heater.

**Note:** When power is turned on or reconnected to the water heater, the red LED will emit a solid glow for three (3) seconds and then extinguish. This is normal operation and does not indicate a fault. The LED display will then return to the current operational status.

The water heater may take up to forty five (45) minutes to commence operating when the power supply is switched on. The heat pump will only operate when power is available at the water heater, the water in the

storage cylinder requires heating, the heat pump compressor is cool and the ambient air temperature is within the heat pump's operating temperature range of between a minimum of 3°C to 5°C and a maximum of 45°C to 55°C. If the ambient temperature is outside of this range, the water heater will commence heating with the booster heating unit.

When the heat pump is operating, the system will switch to the booster heating unit if the detected ambient air temperature is outside the operating temperature range of between a minimum of 3°C to 5°C and a maximum of 45°C to 55°C.

The system will not switch back to heat pump operation from the booster heating unit if the detected ambient air temperature has moved back within the heat pump's operating temperature range. The heating cycle will be completed by the booster heating unit.

**Note:** The heat pump may not turn on after either having just completed a heating cycle and more hot water is drawn from the water heater or power is shut down to the compressor, either during or at the end of a heating cycle. The heat pump will wait until the compressor has cooled down and the conditions for start up are favourable in order to protect the compressor from damage. This will be a minimum of forty five (45) minutes and may take up to ninety (90) minutes from the last heating cycle.

### **To Turn Off the Water Heater**

---

If it is necessary to turn off the water heater:

1. Switch off the electrical supply at the isolating switch to the water heater
2. Close the cold water isolation valve at the cold water inlet to the water heater.

### **Temperature Adjustment**

---

The thermostat controlling the heat pump and the electric booster are factory set and are not adjustable.

### **Other Important Information**

---

#### **Going Away?**

If you plan to be away from home for one or two nights, we suggest you leave the water heater switched on. However, If you plan to stay away more than a few nights, conserve energy by switching the water heater off at either the switchboard or isolating switch (if fitted) (refer to "To Turn Off the Water Heater" on page 5).

Refer to "Turning On the Water Heater" on page 4 for notes regarding water heater restarting after being shut down.

#### **Safety**

This water heater is supplied with a thermostat, two over temperature energy cut outs and a combination temperature pressure relief valve. These devices must not be tampered with or removed. The water heater must not be operated unless each of these devices is fitted and is in working order.

The operation of the over temperature cut out on the thermostat indicates a possibly dangerous situation. If the over temperature cut out operates, it must not be reset and the water heater must be serviced by a qualified person.

If the electrical supply conduit to the water heater is damaged, it must be replaced by a qualified person in order to avoid a hazard. Phone Aquamax Service or their nearest Accredited Service Agent to arrange for an inspection.

The Aquamax warranty may not cover faults if relief valves or other safety devices are tampered with or if the installation is not in accordance with these instructions.

**⚠ Warning:** *For continued safety of this water heater it must be installed, operated and maintained in accordance with the Owner's Guide and Installation Instructions. These instructions must be read in conjunction with all other instructions affixed to the appliance and the installation instructions supplied with the heat pump module.*

**⚠ Warning:** *Do not use **aerosols, stain removers and household chemicals** near the water heater whilst it is operating. Gases from some aerosol sprays, stain removers and household chemicals are flammable and/or become corrosive to the materials used in the heat pump system.*

**⚠ Warning:** *Do not store **swimming pool chemicals, household cleaners, etc.**, near the water heater.*

**⚠ Warning:** Ensure the air flow, air inlet louvres and outlet grille are not obstructed in any way at any time.

**⚠ Warning:** This water heater uses 240 V AC electrical power for operation of the control systems and the electrically operated components. The removal of the access cover(s) will expose 240 volt wiring. They must only be removed by a qualified person.

### How Long Will The Water Heater Last?

The water heater is supported by a manufacturer's warranty (refer to page 29). There are a number of factors that will affect the length of service the water heater will provide. These include but are not limited to the water chemistry, the water pressure, the water temperature (inlet and outlet) and the water usage pattern.

### Environment

At the end of the service life of the heat pump water heater and prior to the water heater being disposed of, a person qualified to work with refrigerants must recover the refrigerant from within the sealed system. The refrigerant must not be vented to atmosphere. Phone Aquamax Service or their nearest Accredited Service Agent to arrange for an inspection.

### Precautions

Where damage to property can occur in the event of the water heater leaking, the water heater must be installed in a safe tray. Construction, installation and draining of a safe tray must comply with AS/NZS 3500.4 and all local codes and regulatory authority requirements.

The water heater must be maintained in accordance with the Owner's Guide and Installation Instructions. Refer to "Periodic Maintenance" on page 6.

If this water heater is to be used where an uninterrupted hot water supply is necessary for your application or business, you should ensure that you have back up redundancy within the hot water system design. This should ensure the continuity of hot water supply in the event that this water heater was to become inoperable for any reason. We recommend you seek advice from your plumber or specifier about your needs and building back up redundancy into your hot water supply system.

## Periodic Maintenance

---

### Minor Six Monthly Maintenance

It is recommended minor maintenance be performed every six months by the dwelling occupant.

**⚠ Warning:** Exercise care when operating easing levers as water discharged from the water heater may be of a very high temperature.

Minor maintenance actions:

1. Operate easing lever on the pressure temperature relief valve (refer to "Pressure Temperature Relief Valve" on page 7).
2. Operate easing lever on expansion control valve (if ECV fitted) (refer to "Expansion Control Valve" on page 7).
3. If a safety tray is installed, check to ensure the safety tray drain pipe is not blocked.

### Major Five Year Service

It is recommended a major five year service be conducted on the water heater.

Servicing must be performed by a qualified person. Phone Aquamax Service or their nearest Accredited Service Agent.

**Note:** The five year service and routine replacement of any components, such as the anode and relief valves, are not included in the Aquamax warranty. A charge will be made for this work.

Major five year service actions:

1. Replace pressure temperature relief valve.
2. Inspect and flush expansion control valve (if fitted) and replace expansion control valve if required.
3. Inspect and if required, replace the anode. If the anode is not replaced, it should be replaced within three years of this service (refer to "Anode" on page 7).

4. Check the electric heating unit for excessive calcium build up or corrosion and replace heating unit if required.
5. Check and inspect the heat pump module for operation.
6. Visually check the unit for any potential problems.
7. Inspect all plumbing and electrical connections.
8. Check the condensate drain to ensure it is not blocked.
9. If a safety tray is installed, check to ensure the safety tray drain pipe is not blocked.

**Note:** The water heater may need to be drained during this service. When switched back on, the water heater will take some time to reheat the water. Depending upon the power supply connection, hot water may not be available until the next day.

### Heat Pump System

It is recommended the evaporator and refrigeration system is checked every five years. In particularly dusty environments, it may be necessary to have the heat pump system checked and cleaned of dust and residue on a more regular basis.

### Pressure Temperature Relief Valve (PTR Valve)

The PTR valve is near the top of the storage cylinder and is essential for safe operation. It is possible for the PTR valve to release a little water through the drain line during each heating period. This occurs as the water is heated and expands by approximately 1/50 of its volume.

Continuous leakage of water from the PTR valve and its drain line may indicate a problem with the water heater (refer to "Pressure Temperature Relief Valve Running" on page 12).

**⚠ Warning:** *Never block the outlet of the PTR valve or its drain line for any reason.*

Operate the easing lever on the PTR valve once every six months. **It is very important you raise and lower the lever gently.**

**⚠ Warning:** *Exercise care when operating easing lever as water discharge from the water heater may be of a very high temperature.*

**⚠ Warning:** *Exercise care to avoid any splashing of water, as water discharged from the drain line will be hot. Stand clear of the drain line's point of discharge when operating the valve's lever.*

**⚠ Danger:** *Failure to perform this procedure may result in the water heater storage cylinder failing, or under certain circumstances, exploding.*

If water does not flow freely from the drain line when the lever is lifted, then the water heater must be checked. Phone Aquamax Service or their nearest Accredited Service Agent to arrange for an inspection.

The pressure temperature relief valve should be replaced at intervals not exceeding 5 years, or more frequently in areas where there is a high incidence of water deposits (refer to "Water Chemistry" on page 8).



### Expansion Control Valve (ECV)

In many areas, including South Australia, Western Australia and scaling water areas, an ECV is fitted to the cold water supply line to the water heater (refer to the "Cold Water Supply Plumbing Arrangement" diagram on page 20). The ECV may discharge a small quantity of water from its drain line during the heating period instead of the PTR valve on the water heater.

Operate the easing lever on the expansion control valve once every six months. **It is very important you raise and lower the lever gently.**

The expansion control valve should be checked for performance or replaced at intervals not exceeding 5 years, or more frequently in areas where there is a high incidence of water deposits (refer to "Water Chemistry" on page 8).

### Anode

The anode installed in your water heater has been designed to slowly dissipate whilst protecting the storage cylinder. If the water heater is not used for two (2) weeks or more, a quantity of hydrogen gas, which is highly flammable, may accumulate in the water heater. To dissipate this gas safely, it is recommended that a hot tap be turned on for several minutes or until discharge of gas ceases. Use a sink, basin, or bath outlet, but

not a dishwasher, clothes washer or other appliance. During this procedure, there must be no smoking, open flame, or any electrical appliances operating nearby. If hydrogen is discharged through the tap, it will probably make an unusual sound similar to air escaping.

The life of the storage cylinder may be extended by arranging a qualified person to periodically inspect the anode and replace if required. If the anode is not replaced during a five year service (refer to "Major Five Year Service" on page 6) then the maximum time after installation when the anode should be replaced for this water heater is 8 years.

For water supplies which are either softened, desalinated or where the water supply may alternate between a water tank and a reticulated public supply or another supply, it is recommended the anode be replaced within 5 years of installation.

### **Change of Water Supply**

The changing or alternating from one water supply to another can have a detrimental effect on the operation and / or life expectation of a number of components in this water heater.

Where there is a changeover from one water supply to another, e.g. a rainwater tank supply, bore water supply, desalinated water supply, public reticulated water supply or water brought in from another supply, then water chemistry information should be sought from the supplier or it should be tested to ensure the water supply meets the requirements given in these guidelines for the Aquamax warranty to apply.

### **Water Chemistry**

---

**This water heater must be installed in accordance with this advice to be covered by the Aquamax warranty.**

This water heater is manufactured to suit the water conditions of most public reticulated water supplies. However, there are some known water chemistries which can have detrimental effects on the water heater and its operation and / or life expectancy. If you are unsure of your water chemistry, you may be able to obtain information from your local water supply authority. This water heater should only be connected to a water supply which complies with these guidelines for the Aquamax warranty to apply.

#### **Total Dissolved Solids (TDS)**

Some water analysis reports may state the conductivity of the water rather than the level of total dissolved solids. Conductivity, measured in microsiemens per centimetre ( $\mu\text{S} / \text{cm}$ ), is directly proportional to the TDS content of the water. TDS, in mg / L, is approximately 70% of the conductivity in  $\mu\text{S} / \text{cm}$ .

The Aquamax warranty will not cover resultant faults to the storage cylinder if this water heater is connected at anytime to a water supply where the TDS content of the water exceeds 600 mg/L. In locations where the water supply TDS exceeds 600 mg/Litre, the magnesium alloy anode (supplied as standard, cap colour code 'Black') should be replaced with an aluminium alloy anode (cap colour code 'Blue'). For more information refer to "Water Chemistry & Anode Type" on page 8.

In locations where TDS approaches 600 mg/L, e.g. due to sediment, we strongly recommend fitting an appropriate filter to ensure water entering or in the water heater does not exceed this level at any time i.e. due to sediment build up.

#### **Water Chemistry & Anode Type**

Aquamax water heaters are designed to suit the water conditions of most metropolitan supplies, where the Total Dissolved Solids (TDS) content of the supply is less than 600 mg/Litre. For use in regions where the water supply TDS exceeds 600 mg/Litre, the magnesium alloy anode (supplied as standard, cap colour code 'Black') may become excessively reactive. For safety reasons and the longevity of the anode, the magnesium anode should be replaced with an aluminium alloy anode (cap colour code 'Blue') available from your Aquamax supplier. Anode replacement must be carried out by an Aquamax accredited service agent.

**⚠ Warning:** *If the water supply has a TDS greater than 600 mg/L and the anode has not been changed to a blue anode, there is the possibility the anode may become overactive and hydrogen gas could accumulate in the top of the water heater during long periods of no use.*

If the water heater has not been used for two or more weeks, follow the procedure detailed in the "Anode" section on page 7 for safe dissipation of the hydrogen gas build up inside the storage cylinder.

It must be noted that in areas where the TDS exceeds 600 mg/Litre, the Aquamax warranty will not cover resultant faults on components including the storage cylinder that fail due to the bad water conditions even

though an aluminium anode is fitted. Refer to “Water Chemistry Levels Affecting Warranty” on page 9 for water chemistry levels and components affected.

The life of the water heater may also be extended by periodic inspection of the anode and replacement if necessary (refer to “Periodic Maintenance” on page 6 and “Anode” on page 7).

### **Water Chemistry Levels Affecting Warranty**

The Aquamax warranty of this water heater will not cover resultant faults if the water supply has a saturation index  $< -1.0$  or  $> 0.4$  (refer to “Scaling Water & Saturation Index” on page 9).

The Aquamax warranty of this water heater will not cover resultant faults on components including the storage cylinder where water stored in the storage cylinder exceeds at any time any of the following levels:

Total dissolved solids	600 mg/Litre
Total hardness	200 mg/Litre
Chloride	250 mg/Litre
Magnesium	10 mg/Litre
pH	9.5 and not less than 6.0
Calcium	20 mg/Litre
Sodium	150 mg/Litre
Iron	1 mg/Litre

### **Scaling Water & Saturation Index**

The saturation index is used as a measure of water’s corrosive or scaling properties.

In a corrosive water supply, water can attack copper parts and cause them to fail. Where the saturation index is less than  $-1.0$ , the water is very corrosive and the Aquamax warranty does not apply to the water heater.

Where the saturation index exceeds  $+0.40$ , the water is very scaling and the Aquamax warranty does not apply to the water heater.

Scaling water is water that contains levels of calcium carbonate (total hardness in excess of 200 mg/Litre at any time when the water heater is operating). Scaling water can block and prevent the pressure & temperature relief valve from operating resulting in damage to the water heater storage cylinder and water heater components.

An expansion control valve is mandatory in SA & WA and must be fitted in ALL areas with scaling water to assist in preventing blockage of the pressure and temperature relief valve.

**⚠ Danger:** *Failure to install an expansion control valve where scaling water conditions occur may result in the water heater storage cylinder failing, or under certain circumstances, exploding.*

To avoid damage to the storage cylinder and water heater components, Aquamax strongly recommend scaling water be treated before entering the water heater by fitting appropriate water filters/conditioners etc. Refer to your Local Water Authority for information on water in your area. A build up of white sediment on hot water taps or shower roses can be indicative of scaling water. Contact Aquamax if this condition is observed.

### **Chloride and Ph**

Where the chloride level exceeds 250 mg/L the Aquamax warranty does not apply to the water heater. In a high chloride water supply, the water can corrode stainless steel parts and cause them to fail.

Where the pH is less than 6.0 or greater than 9.5, the Aquamax warranty does not apply to the water heater. pH is a measure of whether the water is alkaline or acid. In an acidic water supply, the water can attack stainless steel parts and cause them to fail.

Water with a pH less than 6.0 may be treated to raise the pH. The water supply from a rainwater tank in a metropolitan area is likely to be corrosive due to the dissolution of atmospheric contaminants.

### **Spring, Dam, Bore & River Water Supplies**

The Aquamax warranty of this water heater will not cover resultant faults on components including the storage cylinder due to the effects of sludge and/or sediment as a result of connection to a water supply from silted or treated sources i.e. springs, dams, bores, rivers or towns supplied from a bore.

## Troubleshooting

---

Check the items below before making a service call. If the water heater is within the warranty period you will be charged for attending to any condition or fault that is not related to manufacture or failure of a part. For warranty terms and conditions (refer to “Warranty” on page 29).

### Not Enough Hot Water (Or No Hot Water)

- *Is the water heaters electricity supply switched on?*

Have your electrician check to ensure the water heater is switched on and that there is electricity at the water heater.

**Note:** Check the electricity supply to which the water heater is connected. If the water heater is connected to an Off-Peak or time controlled electricity supply, heating hours will be restricted. The HP325-36-1B model water heater is recommended for connection to a minimum 16 hour per day power supply.

- *Is a timer installed?*

If a timer has been installed, ensure sufficient time has been allowed to reheat the storage cylinder.

**Note:** The HP325-36-1B model water heater is recommended for connection to a minimum 16 hour per day power supply.

- *Are you using more hot water than you think?*

Is one outlet (especially the shower) using more hot water than you think? Very often the amount of hot water used is not realised, particularly when showering. Carefully review the family’s hot water usage. Have your plumber install a flow control valve to each shower outlet to reduce water usage.

- *Has the heat pump detected a fault?*

If the heat pump detects certain fault conditions, the water heater will deactivate heat pump operation and switch to backup heating mode to ensure a supply of hot water. In backup heating mode the water in the storage cylinder will be heated by the heating unit and the red LED will provide fault indication by flashing (refer to “Heat Pump is Not Operating” on page 11 and “Operating Mode Monitor LED Indication” on page 14).

- *Pressure temperature relief valve running*

Is the PTR valve discharging too much water? Refer to “Pressure Temperature Relief Valve Running” on page 12.

- *Water heater size*

Do you have the correct size water heater for your requirements? The sizing guide in the sales literature suggests average sizes that may be needed.

### Water Too Hot

During heat pump operation the water in the storage cylinder will be heated to a temperature of 60°C. This is normal operation.

In booster heating mode or back up heating mode the water in the storage cylinder will be heated to 70°C.

**Booster heating mode:** The heat pump will operate when the ambient air temperature is between a minimum of 3°C to 5°C and a maximum of 45°C to 55°C. If the ambient air temperature is outside this temperature range and heating is required, the water heater will deactivate heat pump operation and switch to booster heating mode. In booster heating mode the water in the storage cylinder is heated by the booster heating unit and the green LED will indicate a long flash. This is normal operation (refer to “Operating Mode Monitor LED Indication” on page 14).

**Backup heating mode:** If the heat pump detects certain fault conditions, the water heater will deactivate heat pump operation and switch to backup heating mode to ensure a supply of hot water. In backup heating mode, the booster heating unit will operate if heating of the water is required, regardless of the ambient air temperature. The red LED will flash to indicate the fault mode that has occurred (refer to “Heat Pump is Not Operating” on page 11 and “Operating Mode Monitor LED Indication” on page 14).

## Heat Pump is Not Operating

There must be power available at the water heater and to the heat pump for the heat pump to operate and for the LEDs to glow or flash (for LED information, refer to “Operating Mode Monitor LED Indication” on page 14).

- *Time controlled power supply (no power at the water heater)*

If the water heater is connected to a time controlled power supply, then during periods of no power supply at the water heater the LEDs will be off. This is not a fault condition, but a result of no power being available to energise the LEDs. The green LED will recommence glowing or flashing when power is available again at the water heater.

- *Heat pump operating range (no power to the heat pump)*

The heat pump's operating range is between an ambient air temperature of a minimum of 3°C to 5°C and a maximum of 45°C to 55°C. The heat pump will not operate when the ambient air temperature is outside the heat pump's operating range. If heating is required, the water heater will commence heating with the booster heating unit in booster heating mode (long green flash) instead. The water will be heated to 70°C during these periods.

At the completion of this heating cycle by the booster heating unit (long green flash), the thermostat controlling the booster heating unit opens circuit cutting power to the heat pump causing the green LED to go out. This is not a fault condition, but a result of the power being cut to the heat pump by the thermostat.

The green LED will remain off for an extended period of time until the water temperature in the top of the water heater drops to below 62°C and the thermostat closes circuit reinstating power to the heat pump when the red LED will emit a solid glow for three (3) seconds and then extinguish. The green LED will then recommence to glow or flash.

The green LED will glow (standby mode – water is hot) if the water temperature in the lower part of the water heater is 50°C or more.

The green LED will flash if the water temperature in the lower part of the water heater is less than 50°C. If at least 45 minutes has elapsed after power is reinstated to the heat pump, i.e. 45 minutes after the red LED emitted a solid glow for three (3) seconds and then extinguished, heating of the water by the heat pump will recommence (3 x green flashes) if the ambient air temperature has moved back to within the heat pump's operating range, or the water heater will switch to the booster heating unit (long green flash) if the ambient air temperature is outside of the heat pump's operating range.

- *Thermal cut out activated*

The refrigeration circuit is protected by a thermal sensor. This will activate a thermal cut out in the event of thermal surges or excessive heat in the refrigeration system.

If the thermal cut out activated, the red LED will flash a fault mode of a series of single flashes and the heat pump will not operate. The water heater will switch to backup heating mode using the booster heating unit to ensure a supply of hot water. In backup heating mode the water will be heated to a temperature of 70°C.

The thermal cut out will automatically reset when the booster heating unit has completed one heating cycle and the compressor cools down (refer to “Backup heating mode and series of red flashes” on page 11).

- *Heat pump fault condition*

If the heat pump has developed fault, the heat pump will not operate and the red LED will flash a fault mode of a series of one (1) to nine (9) flashes.

If a series of two (2) red flashes occur, the heat pump will not switch to backup heating mode. Phone Aquamax Service or their nearest Accredited Service Agent to arrange for an inspection.

If a single flash or a series of three (3) to nine (9) red flashes occurs, the water heater will switch to backup heating mode to ensure a supply of hot water (refer to “Backup heating mode and series of red flashes” on page 11).

- *Backup heating mode and series of red flashes*

During the backup heating mode by the booster heating unit, caused by either the thermal cut out activating or a heat pump fault condition, the red LED will emit a series of flashes.

At the completion of a heating cycle by the booster heating unit in the backup heating mode and the water temperature reaches 70°C, the thermostat controlling the booster heating unit opens circuit cutting power to the heat pump causing the red LED to go out. The fault mode is recorded to the heat pump controller's memory. The fault condition which led to the red LED flashing may be cleared when the backup heating cycle has completed.

Both LEDs will remain off for an extended period of time until the water temperature in the top of the water heater drops to below 62°C and the thermostat closes circuit reinstating power to the heat pump.

The red LED will recommence to flash the fault mode for thirty (30) seconds and then extinguish. If the red LED then recommences to flash, the fault condition which led to the red LED flashing may not have cleared and there may be a problem with the heat pump. Count the number of red flashes and phone Aquamax Service or their nearest Accredited Service Agent to arrange for an inspection.

At the end of the thirty (30) second period, the green LED will commence to glow or flash.

The green LED will glow (standby mode – water is hot) if the water temperature in the lower part of the water heater is 50°C or more.

The green LED will flash if the water temperature in the lower part of the water heater is less than 50°C.

**Note:** If the green LED is glowing, then to check whether there may be problem with the heat pump, open a hot tap and allow to run for ten (10) to fifteen (15) minutes. This will draw cold water into the lower part of the water heater and the green LED will commence to flash. Close the hot tap when the green LED commences to flash.

The heat pump will commence to operate when the green LED is flashing and at least 45 minutes has elapsed after power is reinstated to the heat pump, i.e. 45 minutes after the red LED flashed the fault mode for thirty (30) seconds and then extinguished.

If the heat pump stops operating and the red LED recommences to flash, the fault condition which led to the red LED flashing may not have cleared and there may be a problem with the heat pump. Count the number of red flashes and phone Aquamax Service or their nearest Accredited Service Agent to arrange for an inspection.

**Note:** If the ambient air temperature is outside of the heat pump's operating range, the water heater may switch to the booster heating unit (long green flash) to heat the water in booster heating mode.

The fault mode is cleared from the heat pump controller's memory after the water heater successfully completes a full heat up cycle using the heat pump.

- *Green LED is off*

There may be a fault condition with the heat pump if:

- there is power available at the water heater, the green LED is off, and
- the water heater **has not** operated outside of the heat pump's operating range – refer to "Heat pump operating range" on page 11.

Before phoning to arrange a service inspection:

- Inspect the isolating switch marked "HOT WATER" or "WATER HEATER" at the switchboard and the isolating switch (if one is installed) at the water heater and ensure they are turned on
- Check the fuse marked "HOT WATER" or "WATER HEATER" at the switchboard
- If a timer is installed, check the time settings.
- Check the power supply tariff the water heater is connected to confirm power should be available to the water heater.
- Have your electrician check to ensure the water heater is switched on and that there is electricity present at the water heater.

Refer also to "Thermal cut out activated" on page 11 and to "Heat pump fault condition" on page 11.

If the green LED is off and one of these conditions is not the cause, phone Aquamax Service or their nearest Accredited Service Agent to arrange for an inspection.

## **Pressure Temperature Relief Valve Running**

- *Normal Operation*

It is normal and desirable for the PTR valve to allow a small quantity of water to escape during the heating cycle, however there may be a problem if the valve continuously dribbles more than a bucket full of water in a normal 24 hour cycle. **Note:** During the first 24 hours after installation the valve may discharge more than a bucket full of water. This is normal however excess discharge should only occur during the initial 24 hour heat up period.

- *Continuous dribble*

Try gently raising the easing lever on the relief valve for a few seconds (refer to "Pressure Temperature Relief Valve" on page 7). This may dislodge a small particle of foreign matter and clear the fault. Release the lever gently.

- *Steady flows for long periods (often at night)*

This may indicate the mains water pressure sometimes rises above the designed pressure of the water heater. Ask your installing plumber to fit a pressure limiting valve.

**⚠ Warning:** *Never use reconditioned relief valves and never replace the relief valve with one of a higher pressure rating.*

- *Heavy flows of hot water until the water heater is cold - then stops until water reheats*

The water heater **must** be switched off at the isolating switch or switchboard. Phone Aquamax Service or their nearest Accredited Service Agent to arrange for an inspection.

### **Expansion Control Valve Running**

If an expansion control valve is fitted in the cold water supply line to the water heater, it may discharge a small quantity of water instead of the water heaters pressure temperature relief valve. This has the benefit of conserving energy as the discharged water is cooler (refer to the “Cold Water Supply Plumbing Arrangement” diagram on page 20 for expansion control valve location).

### **Higher Than Expected Electricity Bills**

With the installation of your new air sourced heat pump water heater, maximum electrical energy savings can be achieved. Check the following points if your electricity bill is higher than expected:

- *Is the water heater operating in backup heating mode with the red LED flashing?*

If there is a fault condition with the heat pump system, the water heater will default to backup heating mode to ensure a supply of hot water. Check to see if the red LED is flashing as this will indicate there may be a fault with the system (refer to “Heat Pump is not Operating” on page 11).

- *Is the relief valve running excessively?*

Refer to “Pressure Temperature Relief Valve Running” on page 12.

- *Is one outlet (especially the shower) using more hot water than you think?*

Refer to “Not Enough Hot Water” on page 10.

- *Is there a leaking hot water pipe, dripping hot water tap, etc?*

Even a small leak will waste a surprising quantity of hot water and energy. Replace faulty tap washers and have your plumber rectify any leaks.

- *Has there been an increase in hot water usage?*

An increase in hot water usage will result in an increase in heat pump operation.

- *Has your water heating tariff rate been increased by your electricity retailer since your previous bill?*

Check your previous bill and compare electricity rates and charges.

- *Is the heat pump water heater on the same tariff as the water heater replaced?*

The impact on an electricity account will depend upon the tariff arrangement of the water heater replaced and where you live. Contact your energy provider for more information on tariff arrangements and cost comparisons.

- *Has the ambient air temperature been very cold or very hot?*

Prolonged periods of use when the ambient air temperature is outside of the heat pumps operating range will increase the amount of boosting and increase running costs.

**If you have checked all the previous troubleshooting points and still believe you need assistance, phone Aquamax Service or their nearest Accredited Service Agent.**

## Operating Mode Monitor LED Indication

An operating mode monitor is located on the front of the heat pump module and houses a green and a red LED.

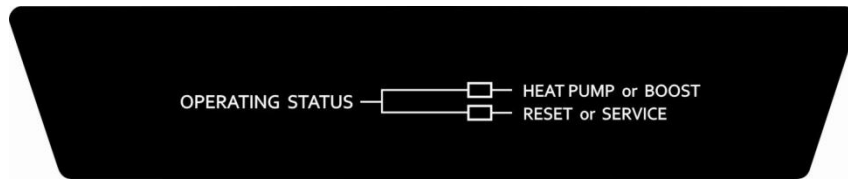

The green LED, marked “HEAT PUMP or BOOST”, indicates the current operating mode of the heat pump water heater and the red LED, marked “RESET or SERVICE”, indicates a fault mode.

The green LED will emit either a constant glow or a series of flashes, with a 2 second interval between each series. A series of long green flashes may also be emitted.

The red LED will emit a series of flashes, with a 2 second interval between each series, only if there is a particular fault condition with the system.

### Diagnostic Features of the Heat Pump Controller

Flashes	Operational Mode
solid green (remains on)	Standby mode – water is hot
1 x green	Call for heating received – system checks performed Note: unit may wait and continue flashing until compressor has cooled from its last operation
2 x green	Circulator commences circulation
3 x green	Heat pump operation – compressor and fan running
long green	Heating unit on – ambient air temperature below 3°C to 5°C or above 45°C to 55°C
no green (remains off)	No power at the water heater or to the heat pump or a possible fault condition <b>Refer to notes below before calling for service</b>

Flashes	Fault Mode
1 x red	Heating unit on      compressor over temperature (possible circulator fault)
2 x red	Heating unit off      compressor fault condition
3 x red	Heating unit on      compressor cooling fault condition
4 x red	Heating unit on      tank thermistor fault condition
5 x red	Heating unit on      evaporator thermistor fault condition
6 x red	Heating unit on      compressor thermistor fault condition
9 x red	Heating unit on      compressor fault condition

Heating unit is the electric booster heating unit.

#### Notes:

- **Power must be available at the water heater and to the heat pump for the LEDs to glow or flash.**
- There are no 7 or 8 x red flash fault mode codes.
- When power is turned on or reconnected to the water heater, the red LED will emit a solid glow for three (3) seconds and then extinguish. This is normal operation and does not indicate a fault. The LED display will then return to the current operational status.
- If there is power to the water heater and the green LED is off or the red LED is flashing, this indicates there may be a fault condition with the water heater. The red LED may emit up to nine flashes in each series of flashes (refer to “Possible fault condition” on page 15).
- **Time controlled power supply (power must be available at the water heater)**

If the water heater is connected to a time controlled power supply, then during periods of no power supply at the water heater the LEDs will be off. This is not a fault condition, but a result of no power being available to energise the LEDs. The green LED will recommence glowing or flashing when power is available again at the water heater.

- **Possible fault condition**

There may be a fault condition with the water heater if either:

- there is power available at the water heater and the green LED is off, and
- the water heater **has not** operated outside the heat pump's operating range.

Before phoning to arrange a service inspection due to the green LED being off, refer to "Heat Pump Is Not Operating" on page 11 in the "Troubleshooting" section of this Owner's Guide.

or

- the red LED is flashing - the red LED may emit up to nine flashes in each series of flashes.

The fault condition which led to the red LED flashing may be cleared after the backup heating cycle by the booster heating unit has been completed. When heating is next required the red LED will recommence to flash the fault code for thirty (30) seconds and then extinguish. If the red LED then recommences to flash or recommences to flash after the heat pump next operates, a service call may be required.

Before phoning to arrange a service inspection due to the red LED flashing, refer to "Heat Pump Is Not Operating" on page 11 in the "Troubleshooting" section of this Owner's Guide.

# INSTALLATION

## Installation Overview

This water heater must be installed by a qualified person in accordance with the installation instructions. The installation must comply with the requirements of AS/NZS 3500.4, AS/NZS 3000 and all local codes and regulatory authority requirements.

This heat pump water heater is comprised of the following components:

- Storage cylinder.
- Heat pump module.

For transport and handling (weight) purposes both items are shipped separately and designed to be assembled at the installation site. The water heater must not be operated until both components are assembled. Refer to “Heat Pump and Storage Cylinder Assembly” on page 18.

Take care when handling the heat pump module. The jacket of the heat pump module needs to be handled gently so as not to cause damage.

**Care must be taken during transportation and handling. Do not lay the heat pump module down and do not tilt the heat pump module or the heat pump and storage tank assembly more than 30° from the vertical.** This will displace the compressor lubricating oil. If the heat pump module or heat pump and storage cylinder assembly has been tilted more than 30° from the vertical during handling, it will need one hour to drain back before the power to the water heater can be switched on, otherwise damage to the compressor may result.

All packaging materials must be removed from the water heater prior to its installation. This includes the removal of the cardboard base of the carton from the underside of the water heater.

This water heater is not suitable for pool heating.

## Typical Installation – Outdoor Location

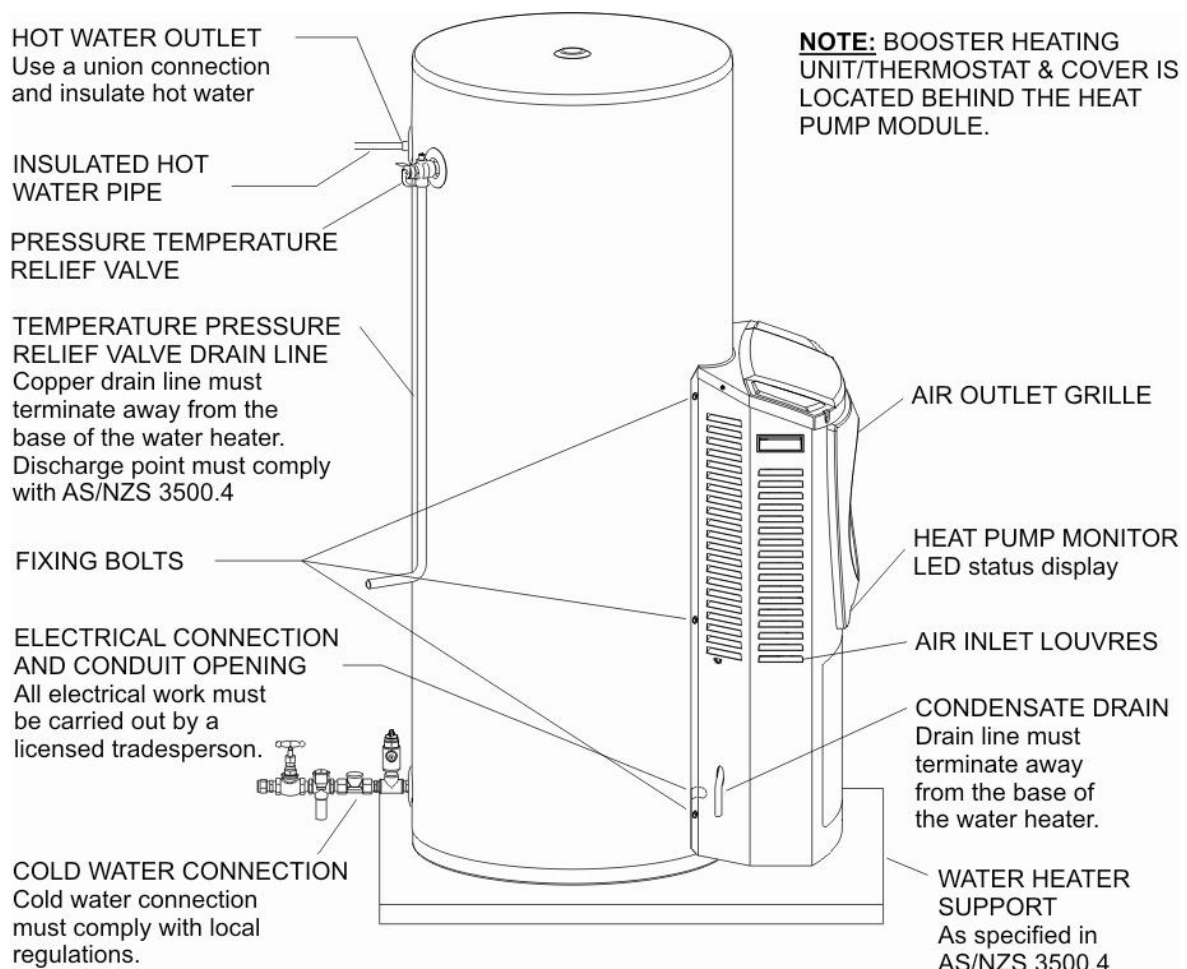

## Victorian Installers

Notice to Victorian Installers from the Victorian Plumbing Industry Commission if this water heater is installed in a new Class 1 dwelling in the State of Victoria. The system model number is to be recorded on the Certificate of Compliance. It is also a requirement to provide the householder with permanent documentation recording the system model number exactly as it is shown in the 'List of systems capable of complying with the regulations' published by Sustainability Victoria (see [www.sustainability.vic.gov.au](http://www.sustainability.vic.gov.au)). This documentation may be in the form of an indelible label adhered to the storage tank, or other suitable form placed in an accessible location, such as the meter box, for later inspection.

## Hot Water Redundancy

If this water heater is to be used where an uninterrupted hot water supply is necessary for the application or business, then there should be redundancy within the hot water system design. This should ensure the continuity of hot water supply in the event that this water heater was to become inoperable for any reason. We recommend you provide advice to the system owner about their needs and building backup redundancy into the hot water supply system.

## Water Supplies

---

### Mains Water Supply

Where the mains water supply pressure exceeds that shown in the table below, an approved pressure limiting valve is required and should be fitted after the stop cock and before the non return valve as shown in the "Cold Water Supply Plumbing Arrangement" diagram on page 20.

Model		HP325-36-1B
Pressure temperature relief valve setting		1000 kPa
Expansion control valve (ECV) setting *		850 kPa
Minimum mains supply pressure		200 kPa
Maximum mains supply pressure	With ECV	680 kPa
	Without ECV	800 kPa

\* Expansion control valve not supplied with water heater.

A minimum water supply pressure of 200 kPa is required to enable the heat pump circulator and heat pump system to operate effectively.

### Tank Water Supply

If the water heater is supplied with water from a tank supply and a minimum water supply pressure of 200 kPa at the water heater cannot be achieved, then a pressure pump system must be installed to allow the heat pump circulator to operate and avoid air locks in the circuit. Care must be taken to avoid air locks. The cold water line from the supply tank should be adequately sized and fitted with a full flow gate valve or ball valve.

### Water Supply Chemistry

Bad water can have a detrimental effect on water heater operation, components and life expectancy and may affect warranty. Refer to "Water Chemistry" on page 8 for more information. Also refer to "Spring, Dam, Bore & River Water Supplies" on page 9.

## INSTALLATION – COMPONENTS

---

This section details the installation of the storage cylinder and heat pump module. To install the water heater plumbing refer to the “Installation – Plumbing & Plumbing Connections” section on page 20.

### Water Heater Location

This water heater is suitable for outdoor installation only. The water heater should be installed close to the most frequently used outlet and its position chosen with noise, safety and service in mind. Make sure people (particularly children) will not accidentally touch the air inlet louvres and outlet grille and that louvres and grille are clear of obstructions and shrubbery.

It is advisable to install the water heater away from bedroom or living room windows as the system controls can generate a level of noise whilst they are operating. Also consider the location in relation to neighbours' bedrooms and living room windows.

Sufficient and safe space for ease of service and access to system controls, heating unit, thermostat, sacrificial anode and relief valves should be considered when locating the water heater. The water heater must be installed at ground level, stand upright in a vertical position and must be accessible without the use of a ladder or scaffold. The base of the water heater is made of corrosion resistant material, and it may be placed directly in contact with the supporting surface. It is not necessary to allow for free air circulation under the base of the water heater.

You must be able to read the information on the rating plate. If possible, leave headroom of one water heater height so the anode can be inspected and / or replaced. If adequate room is unavailable, the water heater must be disconnected, drained and removed to enable servicing.

The heat pump storage cylinder and module must be installed on a level slab or solid base of a minimum 900 mm wide x 650 mm deep. The heat pump module must be fully supported by the level slab or solid base. **Note:** The water heater should not be placed in direct contact with a concrete surface that is less than two months old and not fully cured, as this may attack the metal coating of the water heater base. A moisture barrier should be used between the two surfaces in this instance.

The water heater must be installed with a clearance of at least 100 mm from a wall. A clearance of at least 300 mm is required perpendicular from both the front air inlet louvres and the outlet grille to any wall or obstruction (refer to the dimensional diagram on page 28).

The water heater must not be installed in an area with a corrosive atmosphere where chemicals are stored or where aerosol propellants are released. Remember the air may be safe to breathe, but the chemicals may attack the materials used in the heat pump system.

Do not install this water heater in a roof space as a mains pressure storage water heater.

**Note:** Damage to the storage cylinder caused by incorrect installation is not covered by warranty.

### Heat Pump Module & Storage Cylinder Assembly

---

#### Overview

The heat pump water heater is made of two main components, the storage cylinder and the heat pump module.

For transport and handling (weight) purposes both items are shipped separately and designed to be assembled at the installation site. The water heater must not be operated until both components are assembled.

**⚠ Warning:** The heat pump module is designed to be installed with a purpose built water heater storage cylinder and may not be used for any other purpose.

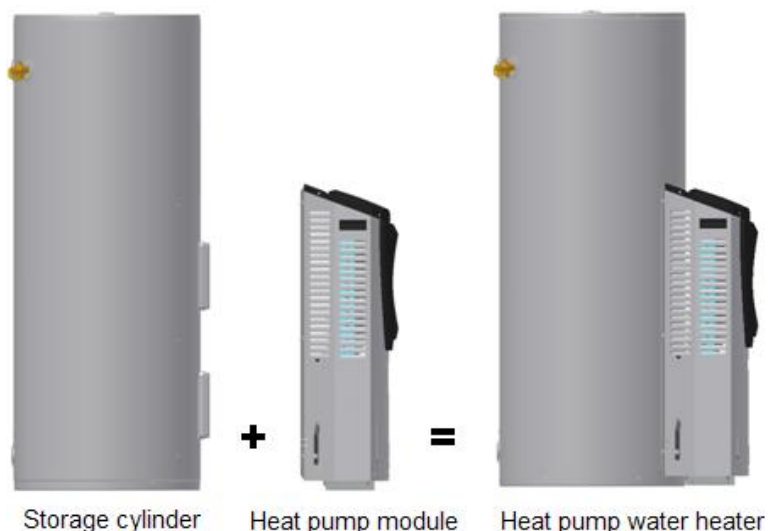

## Heat Pump Module

The heat pump module is shipped in a box containing two hand holes to facilitate easy handling and lifting. The heat pump module is to be mounted against the side of the storage tank and must be fully supported by the level slab or solid base.

**⚠ Warning:** *The heat pump module weighs approximately 37 kg. Use the hand holes provided in the sides of the packaging. Good lifting practice should be followed.*

There are two flexible hoses provided inside the heat pump module. The flexible hoses are to be withdrawn from the module and fixed to the two water fittings on the heat pump storage cylinder during the assembly procedure.

There are two connection points located on the underside of the control box in the heat pump module to which the power cable and tank sensor cable from the heat pump storage cylinder are connected during the assembly procedure.

## Storage Cylinder

The heat pump storage cylinder and module must be installed on a level slab or solid base of a minimum 900 mm wide x 650 mm deep. The storage cylinder is designed to receive the heat pump module.

There are two water fittings located at the side of the storage cylinder to which flexible hoses from the heat pump module are connected, during the assembly procedure.

A power cable and a tank sensor cable are provided behind the lower cover of the storage cylinder. These are to be withdrawn from behind the front cover and connected to the control box in the heat pump module during the assembly procedure.

## Assembly Procedure

**⚠ Warning:** *The heat pump module and storage cylinder must be assembled, plumbed and filled with water prior to power being connected and switched on.*

Refer to the installation instructions supplied with the heat pump module for the heat pump module assembly procedure.

## INSTALLATION – PLUMBING & PLUMBING CONNECTIONS

This section details plumbing, plumbing connections and plumbing diagrams for the water heater. To install the storage cylinder and heat pump module refer to the “Installation – Components” section on page 18.

### Heat Pump Plumbing & Plumbing Connections

All pipe work must be cleared of foreign matter before connection and purged before attempting to operate the water heater. Use thread sealing tape or an approved thread sealant on all fittings (never use hemp).

All Aquamax storage cylinder water fittings have a plastic liner fitted. These liners must be in place for the water heater to function properly. All liners are correctly positioned during manufacture and should not require handling during installation, however if a liner is not correctly inserted or aligned, it should be gently pushed back into place before connecting any plumbing fittings.

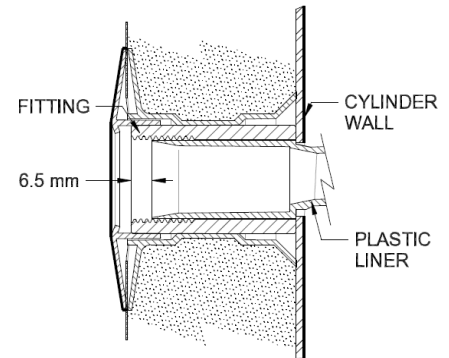

**⚠ Warning:** Plastic liners must be in place for the water heater to function properly. Do not remove or damage liners.

**⚠ Warning:** Do not use heat near plastic liners. Heat can be transferred by conduction which may damage liners.

### Water Inlet & Outlet Connections

An approved isolation valve and non return valve must be installed in the supply line to the water heater.

A pressure limiting valve and expansion control valve may also be required (for PLV requirements refer to “Water Supplies” on page 17 and for ECV requirements refer to “Expansion Control Valve” on page 7).

A disconnection union must always be provided at the cold water inlet and hot water outlet of the water heater to allow for water heater disconnection.

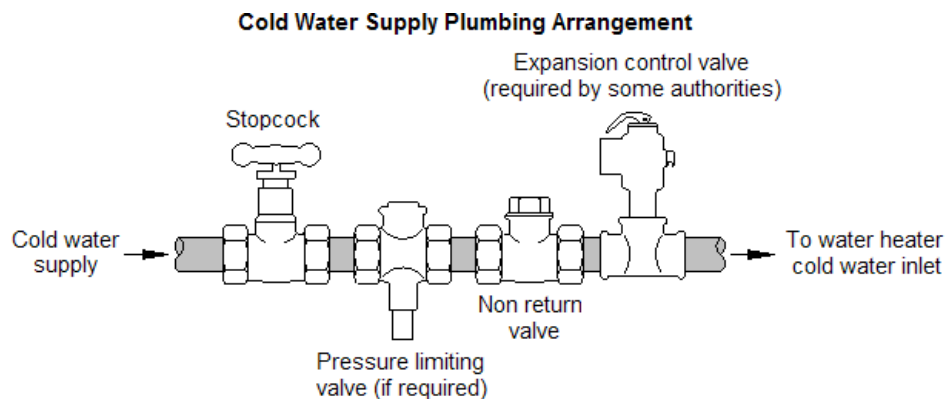

### Expansion Control Valve

In some areas, local regulations may make it mandatory to install an expansion control valve (ECV) in the cold water line to the water heater. In other areas, an ECV is required if the saturation index is greater than +0.4 (refer to “Scaling Water & Saturation Index” on page 9).

The ECV must always be installed after the non return valve and be the last valve installed prior to the water heater (refer to the “Cold Water Supply Plumbing Arrangement” diagram on page 20). A copper drain line must be fitted to the ECV (refer to “Relief Valve Drain(s)” on page 21).

The valve must be insulated with closed cell polymer insulation or similar (minimum thickness 9 mm) and the insulation installed so as not to impede the operation of the valve. The insulation must be weatherproof and UV resistant if exposed.

### Pressure Temperature Relief Valve

The pressure temperature relief (PTR) valve must be fitted before the water heater is operated. Before fitting the PTR valve, make sure the valve probe has not been bent. Seal the valve with thread sealing tape (never use hemp) and ensure the tape does protrude past the end of the thread.

Screw the valve clockwise into the right hand side opening on the storage cylinder marked “PTR” with the valve outlet pointing downwards.

Do not use a wrench on the valve body – use a spanner on the spanner flats. A copper drain line must be fitted to the PTR valve (refer to “Relief Valve Drain(s)” on page 21).

The valve must be insulated with closed cell polymer insulation or similar (minimum thickness 9 mm) and the insulation installed so as not to impede the operation of the valve. The insulation must be weatherproof and UV resistant if exposed.

### **Relief Valve Drain(s)**

DN15 copper drain lines must be fitted to the pressure temperature relief valve and expansion control valve (if one is installed) to carry the discharge clear of the water heater. Connect the drain lines to the valves using disconnection unions. The drain line from the valve to the point of discharge should be as short as possible, have a continuous fall all the way from the water heater to the discharge outlet and have no tap, valves or other restrictions in the pipe work. A drain line from a relief valve must comply with the requirements of AS/NZS 3500.4.

A drain line must be no longer than 9 metres with no more than three bends greater than 45° before discharging at an outlet or air break. The maximum length of 9 metres for a drain line is reduced by 1 metre for each additional bend required of greater than 45°, up to a maximum of three additional bends. Where the distance to the point of final discharge exceeds this length, the drain line can discharge into a tundish.

Subject to local regulatory authority approval, the drain lines from the pressure temperature relief valve and expansion control valve from an individual water heater may be interconnected.

The outlet of a drain line must be in such a position that flow out of the pipe can be easily seen, but arranged so discharge will not cause injury, damage or nuisance. The termination point of a drain line must comply with the requirements of AS/NZS 3500.4. Drain lines must not discharge into a safe tray.

In locations where water pipes are prone to freezing, drain lines must be insulated, must not exceed 300 mm in length and are to discharge into a tundish through an air gap of between 75 mm and 150 mm.

If a drain line discharges into a tundish, the drain line from the tundish must be not less than DN20. The drain line from a tundish must meet the same requirements as for a drain line from a relief valve.

**⚠ Warning:** *As the function of the pressure temperature relief valve on this water heater is to discharge high temperature water under certain conditions, it is strongly recommended the pipe work downstream of the relief valve be capable of carrying water exceeding 93°C. Failure to observe this precaution may result in damage to pipe work and property.*

### **Condensate Drain**

A drain line should be fitted to the heat pump module’s condensate drain to carry the discharge clear of the water heater. The drain line can be extended using 12 mm rigid poly hose or conduit. The pipe work from the condensate drain should be as short as possible and fall all the way from the water heater with no restrictions. It should have no more than three right angle bends in it. The outlet of the drain line must be in such a position that flow out of the pipe can be easily seen - but arranged so water discharge will not cause damage or nuisance.

**The condensate drain line must not be connected to the relief valves drain lines but may discharge at the same point.**

### **Safe Tray**

Where damage to property can occur in the event of the water heater leaking, the water heater must be installed in a safe tray. Construction, installation and draining of a safe tray must comply with AS/NZS 3500.4 and all local codes and regulatory authority requirements. AS/NZS 3500.4 also has particular requirements when a safe tray must be installed.

### **Pipe Sizes**

To achieve true mains pressure operation, the cold water line to the water heater should be the same size or larger than the hot water line from the water heater.

Hot water system pipe work must be sized according to the individual application by persons competent to do so. Reference to the technical specifications of the water heater and local regulatory authority requirements must be made.

## Pipe Work Insulation

To reduce heat loss, the cold water line to and the hot water line from the water heater must be insulated in accordance with the requirements of AS/NZS 3500.4. The insulation must be weatherproof and UV resistant if exposed.

## Saddling Pipe Work

To prevent damage to the storage cylinder when attaching pipe clips or saddles to the water heater jacket, we recommend the use of self-drilling screws with a maximum length of 13 mm. Should pre drilling be required, extreme caution must be observed when penetrating the jacket of the water heater. If the storage cylinder is damaged as a result of attaching pipe clips or saddles to the jacket, any resultant faults will not be covered by the Aquamax warranty.

## General Plumbing Arrangement & Plumbing Diagrams

### Two Temperature Zones Using a Temperature Limiting Device

This water heater can deliver water at temperatures which can cause scalding. It is necessary and we recommend that a temperature limiting device be fitted between the water heater and the hot water outlets in any ablution area such as a bathroom or ensuite, to reduce the risk of scalding.

The installing plumber may have a legal obligation to ensure the installation of this water heater meets the delivery water temperature requirements of AS/NZS 3500.4 so that scalding water temperatures are not delivered to a bathroom, ensuite or other ablution area.

The temperature limiting device used with a heat pump water heater should have a specified 'minimum temperature differential' between the hot water inlet and the tempered water outlet of no greater than 10°C. Refer to the specifications of the temperature limiting device.

Where a temperature limiting device is installed adjacent to the water heater, the cold water line to the temperature limiting device can be branched off the cold water line either before or after the isolation valve, pressure limiting valve and non return valve to the water heater. If an expansion control valve is required, it must always be installed after the non return valve and be the last valve prior to the water heater.

If a pressure limiting valve is installed on the cold water line to the water heater and the cold water line to a temperature limiting device branches off before this valve or from another cold water line in the premises, then a pressure limiting valve of an equal pressure setting may be required prior to the temperature limiting device.

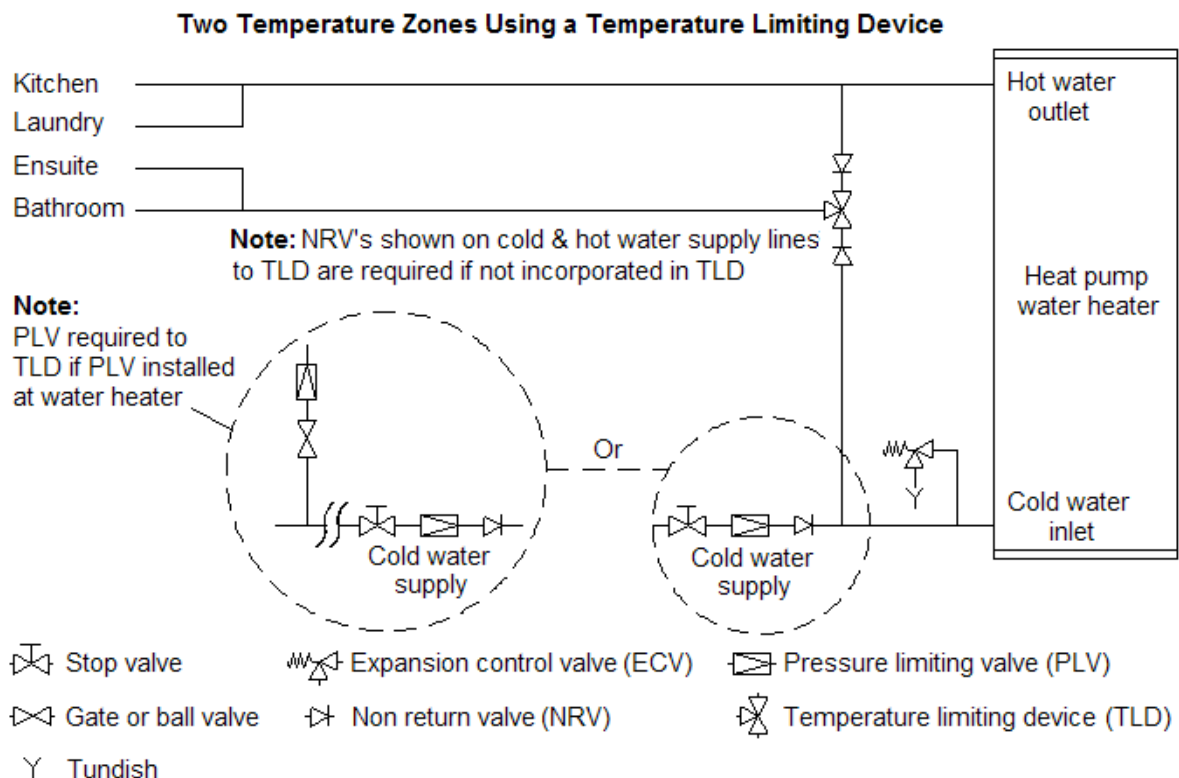

### Circulated Hot Water Flow & Return Systems

The HP325-36-1B heat pump water heater should not be installed as part of a circulated hot water flow and return system in a building.

If a circulated flow and return system is required, it is necessary to bypass the heat pump water heater and install a secondary (booster) water heater connected to the hot water flow and return line and supplied from the heat pump water heater. Aquamax EM50 model water heaters are suitable for use as the secondary water heater provided it has been determined that hot water demand can be met (the secondary water heater has been suitably sized) and the EM50 thermostat has been set to 70°C to meet the requirements of AS 3498. **Note:** The EM50 thermostat factory setting is 70°C.

For circulated hot water flow and return systems, a temperature limiting device can only be installed on a dead leg which branches off the circulated hot water flow and return pipe.

**⚠ Warning:** Installing a temperature limiting device in the circulated flow and return pipe work, or circulating tempered water from a temperature limiting device may cause water to be delivered to ablution areas at a temperature exceeding the requirements of AS/NZS 3500.4.

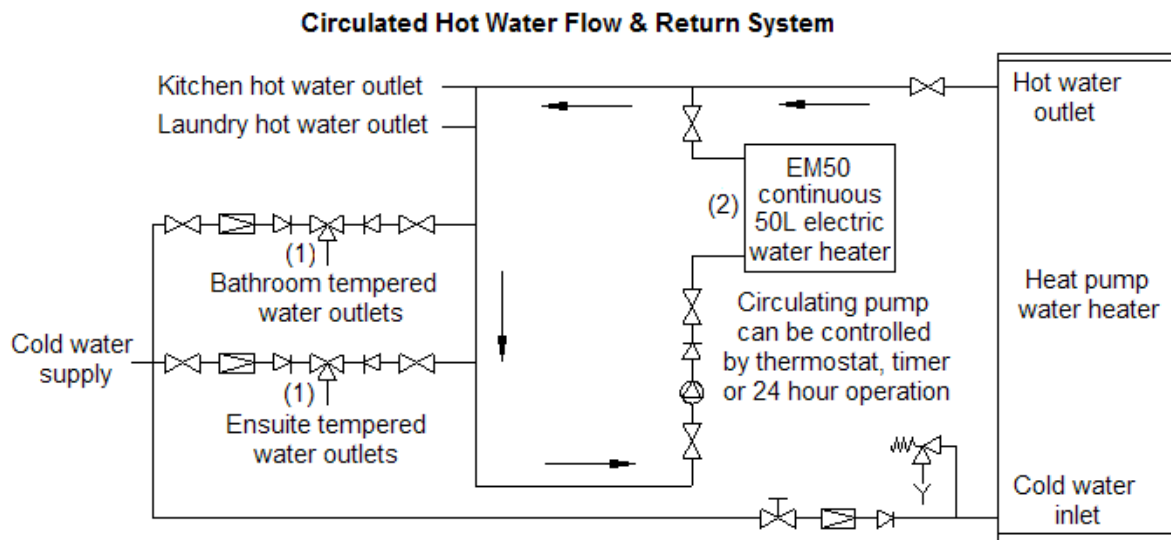

- |                    |                               |                                   |
|--------------------|-------------------------------|-----------------------------------|
| Stop valve         | Expansion control valve (ECV) | Pressure limiting valve (PLV)     |
| Gate or ball valve | Non return valve (NRV)        | Temperature limiting device (TLD) |
| Circulating pump   | Tundish                       |                                   |

**Notes:**

- (1) NRV's shown on cold & hot water supply lines to TLD's are required if not incorporated in TLD.
- (2) EM50 thermostat must be set at 70°C to deliver 60°C.

## INSTALLATION – ELECTRICAL & ELECTRICAL CONNECTIONS

### Heat Pump Electrical & Electrical Connections

**⚠ Warning:** The power supply to the water heater must not be switched on until the water heater is filled with water and a satisfactory megger reading is obtained.

#### Megger Reading

When a megger test is conducted on this water heater, then the following should be noted.

**⚠ Warning:** This water heater contains electronic equipment and 500 V insulation tests must only be conducted between active and earth and between neutral and earth. An active to neutral test WILL damage the electronics.

**An insulation test result of between 100 KΩ and 660 KΩ for this water heater is normal.**

Typically the insulation resistance between live and earthed parts of an electrical installation should not be less than 1 MΩ. However AS/NZS 3000:2000 clause 6.3.3.3.2 'Results' states:

"The value of 1 MΩ may be reduced to:

- 0.01 MΩ for sheathed heating elements or appliances; or
- a value permitted in the Standard applicable to electrical equipment."

This model water heater is categorised as a 'stationary class 1 motor operated appliance' and has been tested to AS/NZS 3350.1:2002 clause 16 'Leakage current and electric strength' and has passed the requirements of this Standard. Therefore, this model water heater complies with the condition stated in AS/NZS 3000:2000 clause 6.3.3.3.2 (b).

#### Electrical Connection

All electrical work and permanent wiring must be carried out by a qualified person and in accordance with the Wiring Rules AS/NZS 3000 and all local codes and regulatory authority requirements.

The water heater must be directly connected to a 240 V AC 50 Hz mains power supply. The water heater must be on its own circuit with an isolating switch installed at the switchboard. A secondary isolating switch may be installed within reach of the water heater.

This water heater is recommended for connection to a minimum 16 hour per day power supply.

A flexible 20mm conduit is required to protect the wiring to the water heater. The conduit is to be connected to the water heater with an approved 20mm flexible conduit terminator. Connect the power supply wires directly to the terminal block and earth tab connection, ensuring there are no excess wire loops inside the front cover.

The water heater will only operate on a sine wave at 50 Hz. Devices generating a square wave cannot be used to supply power to the water heater.

#### Booster Heating Unit

The water heater has a booster heating unit and thermostat. The booster heating unit will be automatically activated during periods when the ambient air temperature is outside the heat pump's operating temperature range of between a minimum of 3°C to 5°C and a maximum of 45°C to 55°C and heating of the water is required.

#### Booster Thermostat Adjustment

**⚠ Warning:** The thermostat and its protective over temperature cut out are mounted inside the front cover(s) of the water heater. The removal of the front cover(s) will expose 240V wiring. Access covers must only be removed by an electrician or qualified person.

The thermostat is set to 70°C and is non adjustable.

#### Over Temperature & Energy Cut Out

The operation of the over temperature and energy cut out on the booster thermostat indicates a possibly dangerous situation. If the over temperature and energy cut out operates, it must not be reset and the water heater must be serviced by a qualified person

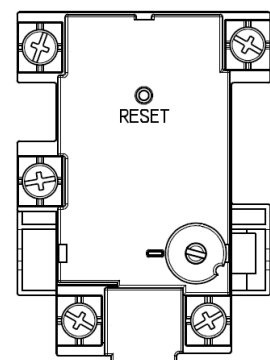

## Timer

A timer can be installed in the electrical circuit to the water heater. The timer must be weatherproof if it is installed outdoors.

It may be desirable for the water heater not to operate between certain hours, such as during the peak period when connected to a Time of Use electricity supply due to a more expensive tariff rate applying. A timer will affect the operating times of both the heat pump circuit and the booster heating unit.

**Note:** The HP325-36-1B model water heater is recommended for connection to a minimum 16 hour per day power supply.

## Wiring Diagram

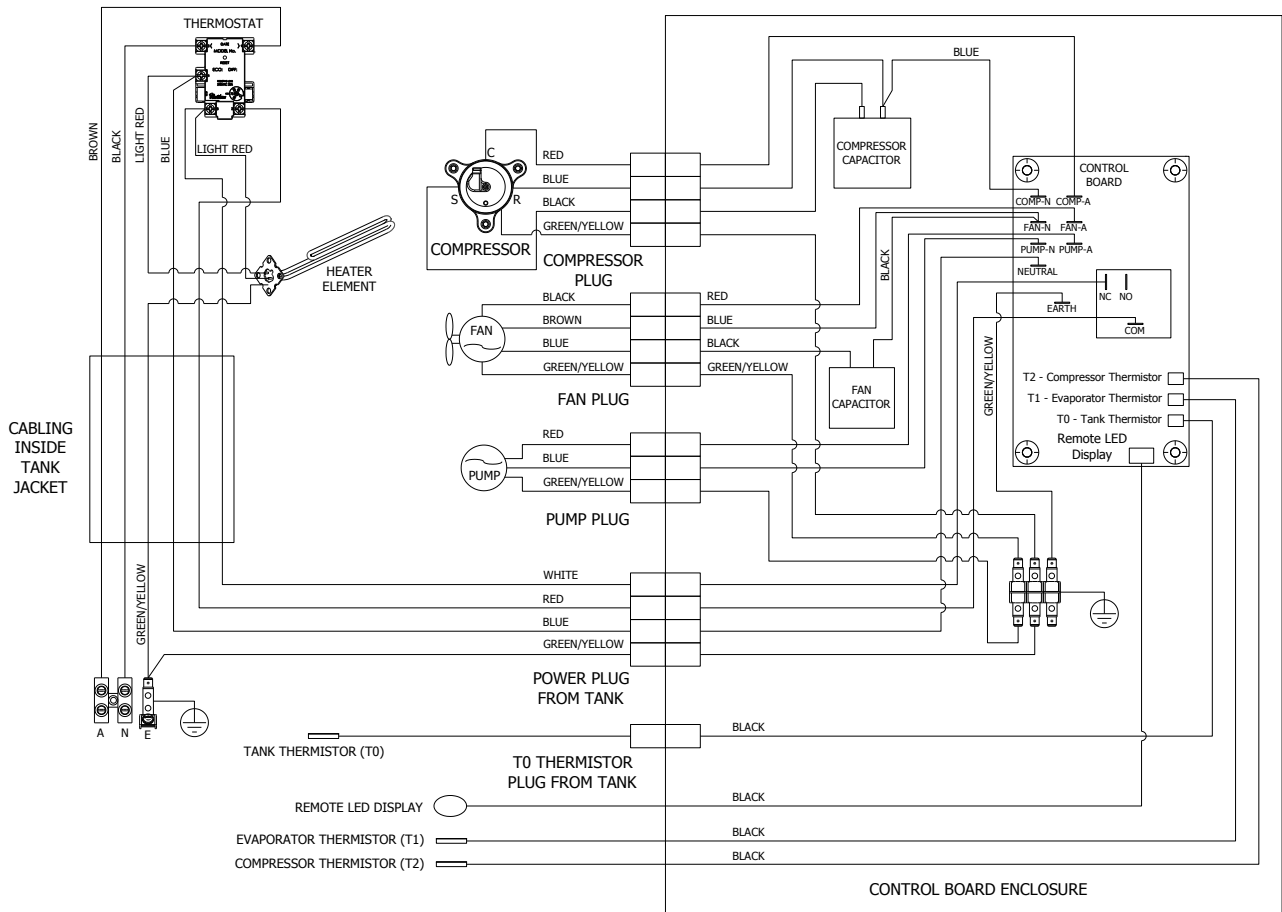

**Electrical Circuit for Heat Pump – Robertshaw “ST” Thermostat**

## COMMISSIONING

---

After installation and before commissioning the water heater the following pre commissioning procedure must be performed:

1. Check to ensure that all wiring links and electrical connections are secure and tight.
2. To ensure the over temperature and energy cut out is set, press and release the black reset button on the booster thermostat (refer to diagram in "Booster Thermostat Adjustment" on page 24).
3. Perform a megger (insulation) test on the water heater. If a satisfactory megger reading is obtained the water heater can be filled and turned on.

### To Fill & Turn On the Water Heater

**⚠ Warning:** *The power supply to the water heater must not be switched on until the water heater is filled with water and a satisfactory megger reading is obtained.*

1. Open all of the hot water taps in the house (don't forget the shower).
2. Open the cold water isolation valve fully to the water heater. Air will be forced out of the taps.
3. Close each tap as water flows freely from it.
4. Check the pipe work and the connection points for the flexible braided hoses for leaks.
5. Switch on the electrical supply at the isolating switch to the water heater.
6. Set the timer if one is installed. **Note:** The HP325-36-1B model water heater is recommended for connection to a minimum 16 hour per day power supply.

**Note:** The water heater is preset in the factory to allow it to commence operating with either the heat pump or booster heating unit immediately power is turned on for the first time. If power is turned on and then off at its installation, the water heater may take up to forty five (45) minutes to commence operating when the power supply is switched on again.

The heat pump will only operate when power is available at the water heater, the water in the storage tank requires heating, the heat pump compressor is cool and the ambient air temperature is within the heat pump's operating temperature range of between a minimum of 3°C to 5°C and a maximum of 45°C to 55°C. If the ambient temperature is outside of this range, the water heater will commence heating with the booster heating unit.

When the heat pump is operating, the system will switch to the booster heating unit if the detected ambient air temperature is outside the operating temperature range of between a minimum of 3°C to 5°C and a maximum of 45°C to 55°C.

The system will not switch back to heat pump operation from the booster heating unit if the detected ambient air temperature has moved back within the heat pump's operating temperature range. The heating cycle will be completed by the booster heating unit.

**Note:** The heat pump may not turn on after either having just completed a heating cycle and more hot water is drawn from the water heater or power is shut down to the compressor, either during or at the end of a heating cycle. The heat pump will wait until the compressor has cooled down and the conditions for start up are favourable in order to protect the compressor from damage. This will be a minimum of forty five (45) minutes and may take up to ninety (90) minutes from the last heating cycle.

It is important to wait for five (5) minutes after the heat pump has activated to ensure it continues to operate and is functioning correctly.

Explain to the householder, or a responsible officer, the functions and operation of the water heater. Leave this guide with the householder or responsible officer upon completion of the installation and after commissioning.

### To Turn Off the Water Heater

If it is necessary to turn off the water heater on completion of the installation, such as on a building site or where the premises are vacant, then:

1. Switch off electrical supply at the isolating switch to the water heater.
2. Close cold water isolation valve at the inlet to water heater.

## Diagnostic Features of the Heat Pump Controller

An operating mode monitor is located on the front of the heat pump module and houses a green and a red LED.

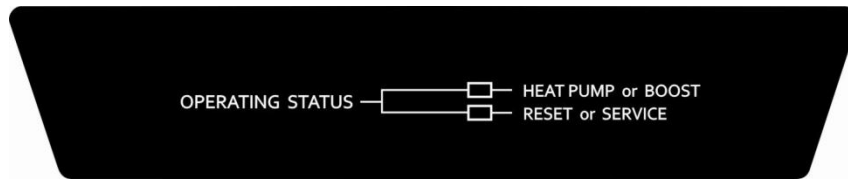

The green LED, marked “HEAT PUMP or BOOST”, indicates the current operating mode of the heat pump water heater and the red LED, marked “RESET or SERVICE”, indicates a fault mode.

The green LED will emit either a constant glow or a series of flashes, with a 2 second interval between each series. A series of long green flashes may also be emitted.

The red LED will emit a series of flashes, with a 2 second interval between each series, only if there is a particular fault condition with the system.

For diagnostic features of the heat pump controller, refer to “Diagnostic Features of the Heat Pump Controller” starting on page 14.

## Draining the Water Heater

---

**⚠ Warning:** *Water discharged from the water heater during this procedure may be of a very high temperature. Wear personal protective equipment to reduce the risk of scalding.*

To drain the water heater:

1. Switch off the electrical supply at the isolating switch to water heater.
2. Close cold water isolation valve at the inlet to the water heater.
3. Close all hot water taps in premises.
4. Operate PTR valve lever for a period of five seconds to release pressure in water heater. **Note:** Operate lever gently and do not let lever snap back or you will damage relief valve seat.
5. Undo union at cold water inlet to water heater and attach a hose to water heater side of union. Run other end of hose to a drain.
6. Operate PTR valve lever until all water has drained from water heater. Operating PTR valve lever will let air into the water heater which will allow water to drain through hose.

## Dimensions & Technical Data

### HP325-36-1B Model

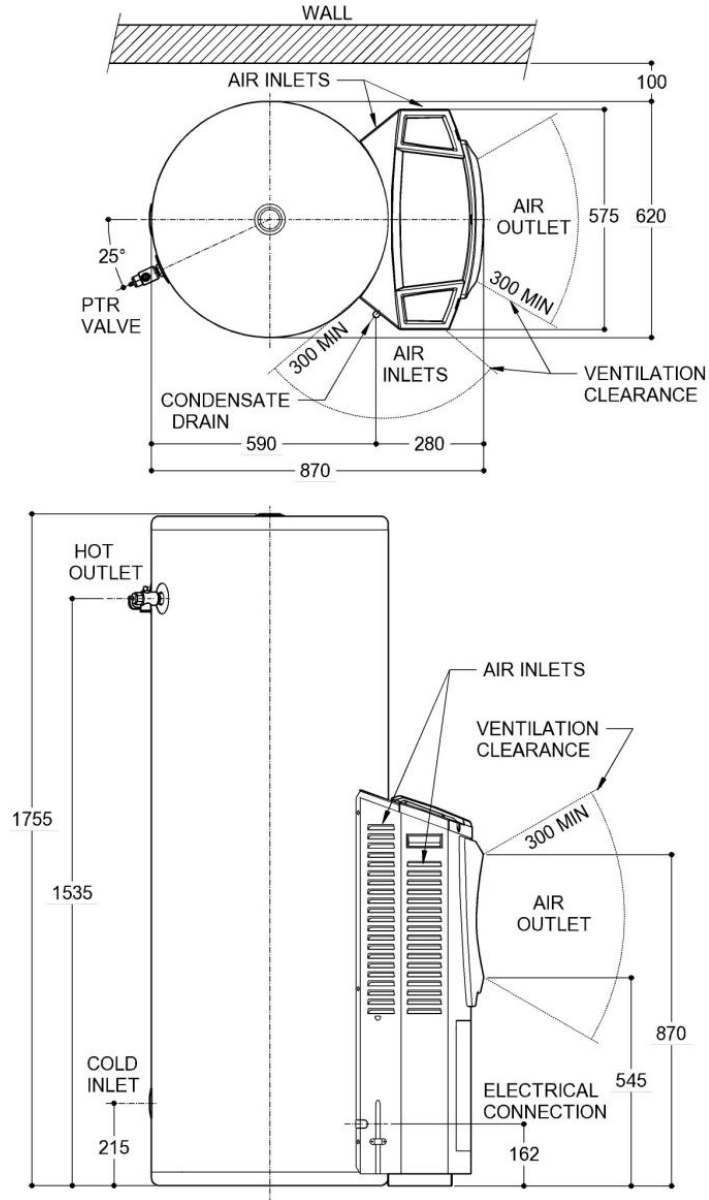

Heat Pump Water Heater System		HP325-36-1B
Storage Cylinder Model		HP325S36
Capacity (L)		325
Boost capacity (L)		206
Booster rating (kW)		3.6
Weight (kg)	(Tank) Empty	90
	(System) Empty	127
	(System) Full	452
Maximum supply pressure	With ECV (kPa)	680
	Without ECV (kPa)	800
Minimum supply pressure (kPa)		200
ECV setting (kPa)		850
PTR valve (kPa)		1000
Heat Pump Module Model		AQ9290000
Weight (kg)		37
Max rated power input (kW)		3.6
Rated heat pump power input (watts)		800
Refrigerant type		R134a
Refrigerant pressure (kPa)		3000

Technical data is subject to change.

# WARRANTY

---

## HEAT PUMP WATER HEATER MODEL HP325-36-1S

### 1. THE AQUAMAX WARRANTY – GENERAL

- 1.1 This warranty is given by Aquamax Australia Pty Limited, ABN 37 138 189 689 of 463-467 Warrigal Road, Moorabbin Victoria.
- 1.2 Aquamax offer a trained and qualified service network who will repair or replace components at the address of the water heater subject to the terms of the Aquamax warranty. Aquamax Service, in addition can provide preventative maintenance and advice on the operation of your water heater. The Aquamax Service contact number is available 7 days a week on 1800 676 000 from 9am to 5pm, excluding public holidays (hours subject to change without notification)
- 1.3 For details about this warranty, you can contact us on 1800 676 000 or by email at [service@aquamax.com.au](mailto:service@aquamax.com.au) (not for service bookings).
- 1.4 The terms of this warranty are set out in section 2 and apply to water heaters manufactured after 1st January 2012.
- 1.5 If a subsequent version of this warranty is published, the terms of that warranty will apply to water heaters manufactured after the date specified in the subsequent version.

### 2. TERMS OF THE AQUAMAX WARRANTY AND EXCLUSIONS TO IT

- 2.1 The decision of whether to repair or replace a faulty component is at Aquamax's sole discretion.
- 2.2 If you require a call out and we find that the fault is not covered by the Aquamax warranty, you are responsible for our standard call out charge. If you wish to have the relevant component repaired or replaced by Aquamax, that service will be at your cost.
- 2.3 Where a failed component or cylinder is replaced under this warranty, the balance of the original warranty period will remain effective. The replacement does not carry a new Aquamax warranty.
- 2.4 Where the water heater is installed outside the boundaries of a metropolitan area as defined by Aquamax or further than 25 km from either a regional Aquamax branch office or an Accredited Aquamax Service Agent's office, the cost of transport, insurance and travelling between the nearest branch office or Aquamax Accredited Service Agent's office and the installed site shall be the owner's responsibility.
- 2.5 Where the water heater is installed in a position that does not allow safe or ready access, the cost of that access, including the cost of additional material handling and/or safety equipment, shall be the owner's responsibility. In other words, the cost of dismantling or removing cupboards, doors or walls and the cost of any special equipment to bring the water heater to floor or ground level or to a serviceable position is not covered by this warranty.
- 2.6 This warranty only applies to the original and genuine Aquamax water heater in its original installed location and any genuine Aquamax replacement parts.
- 2.7 The Aquamax warranty does not cover faults that are a result of:
  - a) Accidental damage to the water heater or any component (for example: (i) Acts of God such as floods, storms, fires, lightning strikes and the like; and (ii) third party acts or omissions).
  - b) Misuse or abnormal use of the water heater.
  - c) Installation not in accordance with the Owner's Guide and Installation Instructions or with relevant statutory and local requirements in the State or Territory in which the water heater is installed.
  - d) Connection at any time to a water supply that does not comply with the water supply guidelines as outlined in the Owner's Guide and Installation Instructions.
  - e) Repairs, attempts to repair or modifications to the water heater by a person other than Aquamax Service or an Aquamax Accredited Service Agent.
  - f) Faulty plumbing or faulty power supply.
  - g) Failure to maintain the water heater in accordance with the Owner's Guide and Installation Instructions.
  - h) Transport damage.
  - i) Fair wear and tear from adverse conditions (for example, corrosion).
  - j) Cosmetic defects.
- 2.8 Subject to any statutory provisions to the contrary, this warranty excludes any and all claims for damage to furniture, carpet, walls, foundations or any other consequential loss either directly or indirectly due to leakage from the water heater, or due to leakage from fittings and/ or pipe work of metal, plastic or other materials caused by water temperature, workmanship or other modes of failure.
- 2.9 If the water heater is not sized to supply the hot water demand in accordance with the guidelines in the Aquamax water heater literature, any resultant fault will not be covered by the Aquamax warranty.

### 3. WHAT IS COVERED BY THE AQUAMAX WARRANTY FOR THE WATER HEATERS DETAILED IN THIS DOCUMENT

3.1 Aquamax will repair or replace a faulty component of your water heater if it fails to operate in accordance with its specifications as follows:

What components are covered	The period in which the fault must appear in order to be covered	What coverage you receive
All components	Year 1	Repair and/or replacement of the faulty component, free of charge, including labour.
<b>Sealed System*</b> components (only if the water heater is installed in a single-family domestic dwelling)	Year 2	Repair and/or replacement of the faulty component, free of charge, including labour.
<b>The cylinder</b> (if the water heater is installed in a single-family domestic dwelling)	Years 2 to 5	Replacement cylinder, free of charge. Installation and repair labour costs are the responsibility of the owner.
<b>The cylinder</b> (if the water heater is <u>not</u> installed in a single-family domestic dwelling)	Year 1	Repair and/or replacement of the faulty component, free of charge, including labour

\* The Sealed System includes components that carry refrigerant only, e.g. Compressor, Condenser, TX Valve, Receiver / Drier, Evaporator and associated pipe work

3.2 If a government rebate has been received for the water heater, the duration of the protection afforded by this warranty may be greater than what is set out above. Please call 1800 676 000 for details.

#### 4. Entitlement To Make A Claim Under This Warranty

- 4.1 To be entitled to make a claim under this warranty you need to:
- Be the owner of the water heater or have consent of the owner to act on their behalf.
  - Contact Aquamax Service without undue delay after detection of the defect and, in any event, within the applicable warranty period.
- 4.2 You are not entitled to make a claim under this warranty if your water heater:
- Does not have its original serial numbers or rating labels.
  - Is not installed in Australia.

#### 5. How To Make A Claim Under This Warranty

- 5.1 If you wish to make a claim under this warranty, you need to:
- Contact Aquamax on 1800 676 000 and provide owner's details, address of the water heater, a contact number and date of installation of the water heater or if that's unavailable, the date of manufacture and serial number (from the rating label on the water heater).
  - Aquamax will arrange for the water heater to be tested and assessed on-site.
  - If Aquamax determines that you have a valid warranty claim, Aquamax will repair or replace the water heater in accordance with this warranty.
- 5.2 Any expenses incurred in the making of a claim under this warranty will be borne by you.

#### 6. The Australian Consumer Law

- 6.1 Our goods come with guarantees that cannot be excluded under the Australian Consumer Law. You are entitled to a replacement or refund for a major failure and for compensation for any other reasonably foreseeable loss or damage. You are also entitled to have the goods repaired or replaced if the goods fail to be of acceptable quality and the failure does not amount to a major failure.
- 6.2 The Aquamax warranty (set out above) is in addition to any rights and remedies that you may have under the Australian Consumer Law.

## INSTALLER INFORMATION

DEAR INSTALLER,

Please provide the following information upon completion of the installation. This information should be provided to assist the customer in the event that a claim is made under the Aquamax warranty.

**Plumber (Name & Company):**

---

**Plumber's licence number:**

---

**Compliance Certificate:**

*(if applicable in your state)*

---

**Installation date:**

---

**Model & serial number:**

---

**Water Heater date of manufacture:**

---

<b>AQUAMAX AUSTRALIA PTY.LTD</b> ABN 37 138 189 689 www.aquamax.com.au	FOR SERVICE TELEPHONE <b>1800 676 000</b>
--	--